

QL56 Series Luminescence Sensor



Datasheet

High-performance Luminescence Sensor

For the latest technical information about this product, including specifications, dimensions, and wiring, see www.bannerengineering.com.

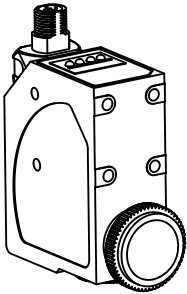

- Senses luminescent marks, even on luminescent backgrounds and irregular or reflective surfaces
- High-power UV emission and a line of structured light provide a uniform and consistent beam for improved sensitivity
- Fast switching frequency and response time
- Push button programming for easy setup and clear bargraph indicator
- Choice of operating distance depending on model
- Durable, compact aluminum housing
- Bipolar (1 NPN & 1 PNP) output, plus 0.75 to 5.5V dc analog output
- 5-position swivel QD connector



WARNING: Not To Be Used for Personnel Protection

Never use this device as a sensing device for personnel protection. Doing so could lead to serious injury or death. This device does not include the self-checking redundant circuitry necessary to allow its use in personnel safety applications. A sensor failure or malfunction can cause either an energized or de-energized sensor output condition.

Models

Model	Operating Distance	Sensor Performance	Cable / Connector	Supply Voltage	Outputs
QL56M6XD15BQ	10 to 20 mm (0.39 in to 0.79 in)	<p>Relative Received Signal vs Sensing Distance</p>	5-pin Euro-style (M12) QD connector	15 to 30 V dc	One NPN and PNP discrete plus one 0.75 to 5.5 V dc analog
QL56M6XD30BQ	20 to 40 mm (0.79 in to 1.57 in)	<p>Relative Received Signal vs Sensing Distance</p>			
QL56M6XD40BQ	30 to 50 mm (1.18 in to 1.97 in)	<p>Relative Received Signal vs Sensing Distance</p>			



Overview

The QL56 Series Luminescence Sensor is an easy-to-use, extremely sensitive luminescence sensor that emits ultraviolet (UV) light from high-power LEDs and detects visible light created by luminescent targets. This technology allows for the detection of luminescent marks (even invisible ones) on any surface, independently from its material, color, or distance inside the operating range, as long as the target radiates visible light when illuminated with UV light.

Applications

The QL56 can be used to error-proof manufacturing lines and verify the presence of glues, lubricants, tamper-proof labels, inks, paint, or the inspector's UV mark. There are many applications where the unique property of luminescence can be used to verify that a chemical or adhesive was applied, to inspect for leaks on a seal, or to ensure a critical manufacturing step was completed.

Many materials exhibit luminescence naturally or can be enhanced to include luminescence dyes (also known as luminophores). For example, white bond paper exhibits luminescence under the UV light without any additional treatment. Or a corrosion prevention treatment may be enhanced to include a luminescence dye so that its application can be verified later.

The Advantage of the QL56

The QL56 sensor uses six UV LEDs which create a uniform and intense line of UV light. The structured light allows for reliable detection of luminescence marks on irregular or textured surfaces such as wood, textile, or cast surfaces. The sensor's durable aluminum housing ensures years of use in challenging environments. Most applications can be addressed with the bi-polar discrete outputs, but an analog output signal is available to make subtle pass or fail decisions if greater contrast resolution is required.

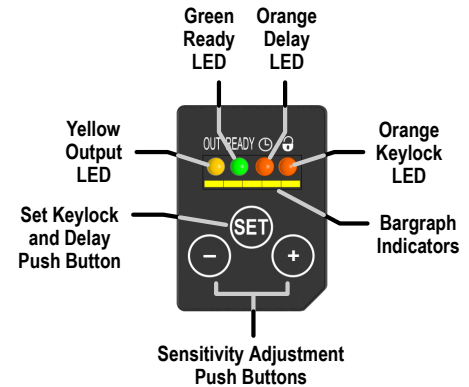

Figure 1. Features

Sensor Configuration

General Notes on Configuration

- The sensor has a KEYLOCK function that deactivates the push buttons to avoid accidental sensor setting. The push buttons are locked at sensor power-up (KEYLOCK LED OFF). To enable the push buttons, press and hold the SET push button for 5 seconds; there is a 2 minute timeout for the keylock.
- The DELAY SETTING extends the minimum active output status duration to 20 ms, allowing slower interface systems to detect shorter pulses.
- The analog output supplies a voltage proportional to the signal received by the sensor. The voltage supplied is 0.75 to 5.5V.

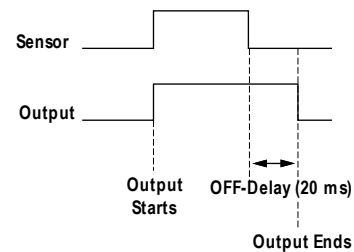
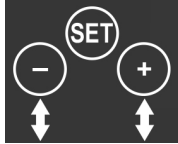

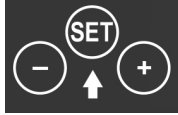



Figure 2. OFF-delay: output continues for 20 ms after sensing stops

	Procedure	Result
Keylock Setting	Press and hold SET push button for 5 seconds (the keyboard will automatically re-lock if inactive for 2 minutes) 	Keylock LED: ON 

	Procedure		Result
Sensitivity Setting	Click the "+" and "-" push buttons to increase or decrease the sensitivity level. Hold for fast adjustment.		Sensitivity Setting communicated by bar graph indicator 
Delay Setting	Press and hold the SET push button for 2 seconds to toggle off-delay		DELAY LED: ON indicating 20 ms off-delay is active 

Installation

The sensor can be mounted using the Ø3.5 mm housing holes or the threaded M5 holes with 6 mm max. depth. (Warning: the use of excessively long screws can damage the product) The connector can be oriented at five different positions by rotating the block. The position chosen is held by a mechanical blocking system. The rotation can be carried out after sensor installation as the connector block is completely self contained inside the housing.

Specifications

Sensing Beam

LED UV, 375 nm; class 1

Sensing Range

QL56M6XD15BQ: 10 to 20 mm (0.39" to 0.79")
 QL56M6XD30BQ: 20 to 40 mm (0.79" to 1.57")
 QL56M6XD40BQ: 30 to 50 mm (1.18" to 1.97")

Supply Voltage and Current

15 to 30V dc (2 Vpp max. ripple); 50 mA max. @ 24V dc (excluding output current)

Supply Protection Circuitry

Protected against reverse polarity

Output Configuration

Bipolar (1 NPN & 1 PNP), plus 0.75 to 5.5V dc analog output

Analog Output

0.75 to 5.5V dc max

Analog Output Impedance

2.2 kΩ (short-circuit protection)

Output Rating

100 mA max.

Output Saturation Voltage

≤ 2V

Output Protection Circuitry

Overload and short circuit protection

Output Response Time

250 μs

Switching Frequency

2 kHz

Delay

0 ms (default) or 20 ms user selectable

Adjustments

"+" and "-" push buttons determine sensitivity
 "Set" push button activates delay and keylock function (see [QL56 Overview](#))

Indicators

Yellow OUTPUT LED: ON indicates output conducting
 Green READY LED: ON indicates power on; Flashing indicates output overload
 Orange DELAY LED: ON indicates 20 ms delay activated
 Orange KEYLOCK LED: ON indicates push buttons are unlocked
 5-segment bargraph: Indicates sensitivity

Construction

Aluminum housing, glass lens; mass 180 g max.

Environmental Rating

IP67

Connections

5-pin Euro-style (M12) integral QD

Operating Conditions

Temperature: - 10° to +55° C (14° to 131° F)
 Storage Temperature: -20° to +70° C (-4° to 158° F)

Minimum Spot Dimension

2 x 8 mm @ 10 mm (QL56M6XD15BQ)
 3 x 11 mm @ 24 mm (QL56M6XD30BQ)
 4 x 15 mm @ 50 mm (QL56M6XD40BQ)

Ambient Light Rejection

According to EN 60947-5-2

Shock Resistance

30 G; 6 shocks per axis; 11 ms duration (EN60068-2-27)

Vibration

0.5 mm amplitude; 10 to 55 Hz frequency, per axis (EN60068-2-6)

Application Notes

The lens must be used in the lower position, and the cap must remain in place on the end position

Certifications



Dimensions

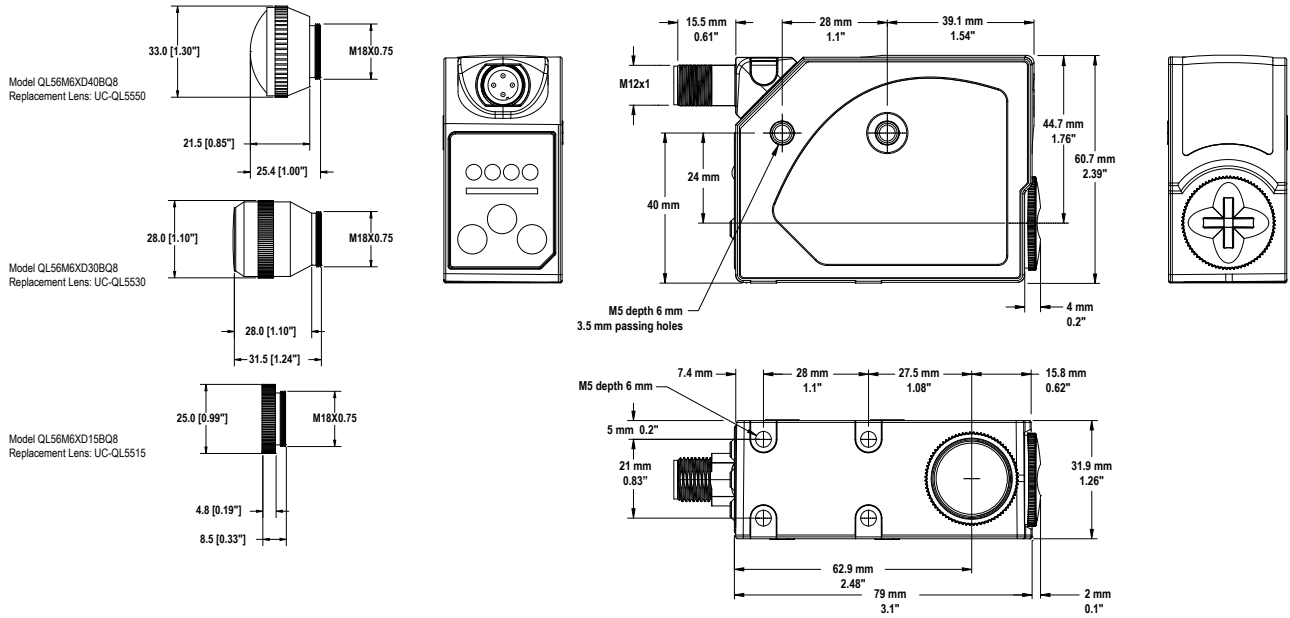

Hookups

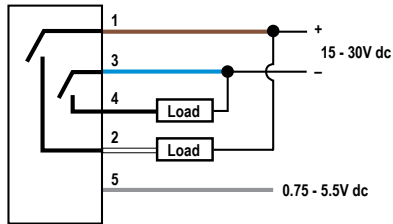

Wiring Key:





- 1 = Brown
- 2 = White
- 3 = Blue
- 4 = Black
- 5 = Gray

Quick-Disconnect Cables

Style	Model	Length	Dimensions	Pinout
5-Pin Straight Euro-Style (M12)	MQDC1-506	2 m (6.5 ft)		
	MQDC1-515	5 m (15 ft)		
	MQDC1-530	9 m (30 ft)		

Pinout details:
 1 = Brown
 2 = White
 3 = Blue
 4 = Black
 5 = Gray

Mounting Brackets

SMB55A	SMB55RA	SMB55F	SMB55S
<ul style="list-style-type: none"> • 15° offset bracket • 12-gauge stainless steel 	<ul style="list-style-type: none"> • Right-angle bracket • 12-gauge stainless steel 	<ul style="list-style-type: none"> • Flat-mount bracket • 12-gauge stainless steel 	<ul style="list-style-type: none"> • 15° offset bracket • 12-gauge stainless steel
			

Banner Engineering Corp Limited Warranty

Banner Engineering Corp. warrants its products to be free from defects in material and workmanship for one year following the date of shipment. Banner Engineering Corp. will repair or replace, free of charge, any product of its manufacture which, at the time it is returned to the factory, is found to have been defective during the warranty period. This warranty does not cover damage or liability for misuse, abuse, or the improper application or installation of the Banner product.

THIS LIMITED WARRANTY IS EXCLUSIVE AND IN LIEU OF ALL OTHER WARRANTIES WHETHER EXPRESS OR IMPLIED (INCLUDING, WITHOUT LIMITATION, ANY WARRANTY OF MERCHANTABILITY OR FITNESS FOR A PARTICULAR PURPOSE), AND WHETHER ARISING UNDER COURSE OF PERFORMANCE, COURSE OF DEALING OR TRADE USAGE.

This Warranty is exclusive and limited to repair or, at the discretion of Banner Engineering Corp., replacement. IN NO EVENT SHALL BANNER ENGINEERING CORP. BE LIABLE TO BUYER OR ANY OTHER PERSON OR ENTITY FOR ANY EXTRA COSTS, EXPENSES, LOSSES, LOSS OF PROFITS, OR ANY INCIDENTAL, CONSEQUENTIAL OR SPECIAL DAMAGES RESULTING FROM ANY PRODUCT DEFECT OR FROM THE USE OR INABILITY TO USE THE PRODUCT, WHETHER ARISING IN CONTRACT OR WARRANTY, STATUTE, TORT, STRICT LIABILITY, NEGLIGENCE, OR OTHERWISE.

Banner Engineering Corp. reserves the right to change, modify or improve the design of the product without assuming any obligations or liabilities relating to any product previously manufactured by Banner Engineering Corp.