

# WLS28-2 Dual Color LED Strip Light

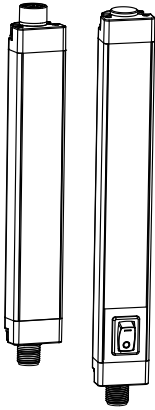

## Datasheet



Banner's LED Strip Lights have sturdy aluminum housings, shatterproof windows, and impressive environmental ratings, making them an ideal general-purpose LED light for machine, enclosure, or other industrial lighting applications. Having two colors in one device make these ideal for mobile vehicle, machine status, and vision lighting applications.

- Low-profile, space-saving design
- Rugged, water-resistant IP69K option
- Available in 4 lengths from 285 to 1130 mm
- Lensed models or choice of clear or diffused window
- Daisy chain power to multiple lights
- Optional snap clips for easy installation and repositioning
- Optional switch for color selection and control
- Automatic temperature protection built into the unit. Above 50 °C, the light dims to manage heat and protect product lifetime



NOTE: When cascading lights, a model with a color selection switch can be used to control the lights cascaded off the switched model.

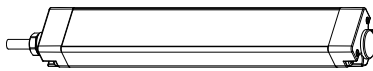

Stand-Alone Light—cable

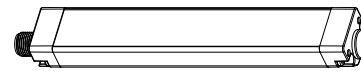

Stand-Alone Light or End Light in a Cascade—QD

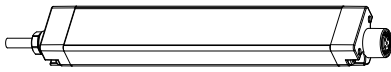

First Light in a Cascade—cable

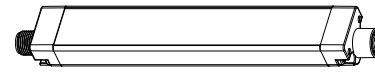

First or Middle of a Cascade—QD

WLS28-2 LED Strip Lights are available as either stand-alone models, or as cascade models that can be "daisy-chained" together for a continuous length of lighting, with a minimum of wiring.

Stand-alone models have cable or male QD fitting at one end for power connection, no connections at opposite end. A stand-alone model may be used as the last in the cascade series.

Cascade models have cable or male QD fitting at one end for power connection, female QD fitting at opposite end for connection to other lights in the cascade. Cascade models with cable end can only be used as the first light in the cascade series. A double-ended accessory cordset must be used between each pair of lights in a cascade.

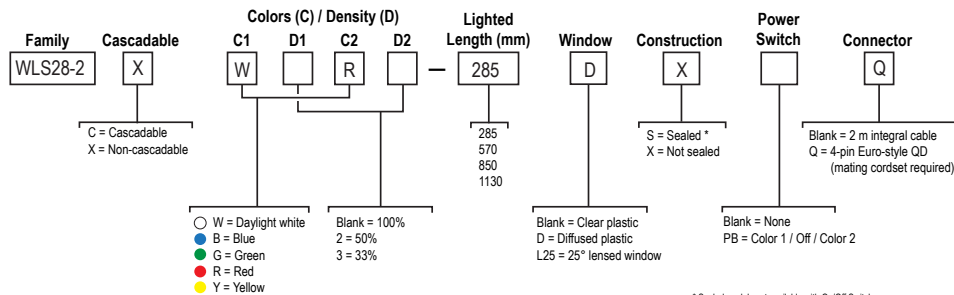

Density (D) is defined by the quantity of LEDs populated on the circuit. For example, at 100% density, there are 18 LEDs per 285 mm, and at 50% density, there are 9 LEDs per 285 mm. The lumen output decreases proportionally with density.



Sample Model Number	Description
WLS28-2XWR-570XQ	Non Cascade, White (100% Density), Red (100% Density), 570 mm, Unsealed, 4-pin M12/Euro-style quick disconnect connector
WLS28-2XWR-285SQ	Non Cascade, White (100% Density), Red (100% Density), 285 mm, Sealed, 4-pin M12/Euro-style quick disconnect connector
WLS28-2CWR-850XQ	Cascadable, White (100% Density), Red (100% Density), 850 mm, Unsealed, 4-pin M12/Euro-style quick disconnect connector
WLS28-2XWR2-1130X	Non Cascade, White (100% Density), Red (50% Density), 1130 mm, Unsealed, 2 m integral cable with flying leads
WLS28-2XWR2-285XPBQ	Non-Cascade, White (100% Density), Red (50% Density), 285 mm, Unsealed, Color 1 /OFF / Color 2 rocker switch, 4-pin M12/Euro-style quick disconnect connector

## Specifications

### Operating Voltage

12 to 30 V dc

Use only with a suitable Class 2 power supply

Light Length	Typical Current			Max. Current
	12 V dc	24 V dc	30 V dc	A
285 mm	0.66 A	0.30 A	0.24 A	0.8
570 mm	1.36 A	0.61 A	0.48 A	1.6
850 mm	2.13 A	0.92 A	0.73 A	2.4
1130 mm	3.04 A	1.24 A	0.97 A	3.2

### Light Characteristics - Daylight White

Color Temperature (CCT): 4700–5300K

Lumen output: 475 (± 5%) per 285 mm, typical at 25 °C (77 °F)

CRI: 83, typical

### Light Characteristics - Other Colors

Color	Typical Wavelength or Color Temperature	Typical Intensity (per 285 mm) <sup>1</sup>
Red	625 nm	200
Yellow	590 nm	150
Green	525 nm	300
Blue	470 nm	110



**NOTE:** Do not spray cable with high-pressure sprayer, or cable damage will result.

### Push Button

II = Color 2

I = Color 1

0 = Off

### Connections

Integral 4-pin Euro-style QD (4-pin connecting cordset required for QD models); or 2 m (6.5 ft) integral cable

### Mounting

(2) swivel brackets SMBWLS28RA included and (4) screws

### Construction

Clear anodized aluminum housing; painted zinc end caps; acrylic window; zinc plated steel brackets

### Environmental Rating

IEC IP50 (non-sealed models) or IEC IP67/IP69K per DIN 40050 (sealed models)

### Vibration and Mechanical Shock

Vibration 10-55 Hz 1.0 mm p-p amplitude per IEC 60068-2-6

Shock 15G 11 ms duration, half sine wave per IEC 60068-2-27

### Operating Temperature

–25 °C to +70 °C (–13 °F to +158 °F)

Light output begins to decrease above 50 °C (122 °F) and will be approximately 65% of max intensity at 60 °C (140 °F) and 30% of max intensity at 70 °C (158 °F)

### Storage Temperature

–40 °C to +70 °C (–40 °F to +158 °F)

### Certifications



### Application Notes

When connecting cascadable lights in series it is important not to exceed maximum current limitations:

Maximum length of light at 12 V dc: 1.4 m (4.6 ft)

Maximum length of light at 24 V dc: 3.0 m (9.8 ft)

Maximum length of light at 30 V dc: 3.1 m (10.2 ft)

<sup>1</sup> Lumen values are reduced by 25% on diffused window models.

## Dimensions

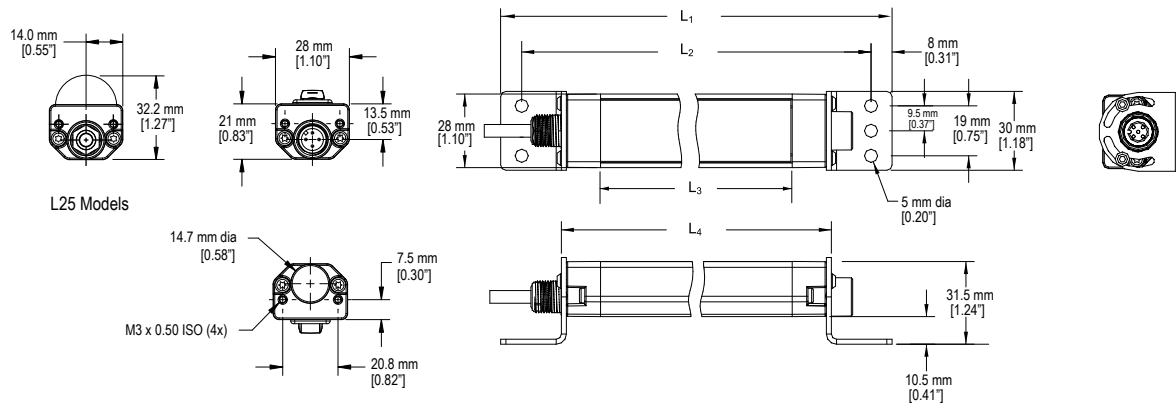

Dimensions are shown with the included SMBWLS28RA bracket.

Non-Switch Models					
IP50 Models	IP67/IP69K Models	L <sub>1</sub>	L <sub>2</sub>	L <sub>3</sub>	L <sub>4</sub>
WLS28-2..285X	WLS28-2..285S	362 mm (14.3 in)	346 mm (13.6 in)	286 mm (11.26 in)	316 mm (12.4 in)
WLS28-2..570X	WLS28-2..570S	644 mm (25.4 in)	628 mm (24.7 in)	568 mm (22.36 in)	598 mm (23.5 in)
WLS28-2..850X	WLS28-2..850S	926 mm (36.5 in)	910 mm (35.8 in)	850 mm (33.46 in)	880 mm (34.6 in)
WLS28-2..1130X	WLS28-2..1130S	1208 mm (47.6 in)	1192 mm (46.9 in)	1132 mm (44.57 in)	1162 mm (45.7 in)

ON/OFF Switch Models				
Model	L <sub>1</sub>	L <sub>2</sub>	L <sub>3</sub>	L <sub>4</sub>
WLS28-2..285XPB	392 mm (15.4 in)	376 mm (14.8 in)	286 mm (11.26 in)	346 mm (13.6 in)
WLS28-2..570XPB	674 mm (26.5 in)	658 mm (25.9 in)	568 mm (22.36 in)	628 mm (24.7 in)
WLS28-2..850XPB	956 mm (37.6 in)	940 mm (37 in)	850 mm (33.46 in)	910 mm (35.8 in)
WLS28-2..1130XPB	1238 mm (48.7 in)	1222 mm (48.1 in)	1132 mm (44.57 in)	1192 mm (46.9 in)

## Wiring Diagram

	Pin	Wire Color	Connection
	1	brown	Color 1: 12 to 30 V dc
	3	blue	dc common
	4	black	Color 2: 12 to 30 V dc (color 2 overrides color 1)
	2	white	Not used

## Accessories

### Cordsets

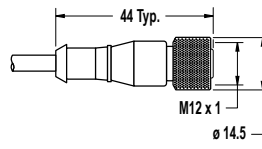
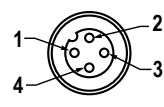
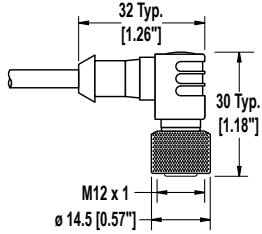

Use single-ended cordsets between the power source and the QD connection of a stand-alone light or the first light in a cascade. Use double-ended cordsets between lights in a cascade.

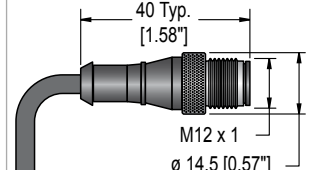
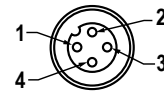
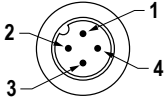
4-Pin Threaded M12/Euro-Style Cordsets				
Model	Length	Style	Dimensions	Pinout
MQDC-406	1.83 m (6 ft)	Straight		
MQDC-415	4.57 m (15 ft)			
MQDC-430	9.14 m (30 ft)			
MQDC-450	15.2 m (50 ft)			
MQDC-406RA	1.83 m (6 ft)	Right-Angle		1 = Brown 2 = White 3 = Blue 4 = Black
MQDC-415RA	4.57 m (15 ft)			
MQDC-430RA	9.14 m (30 ft)			
MQDC-450RA	15.2 m (50 ft)			

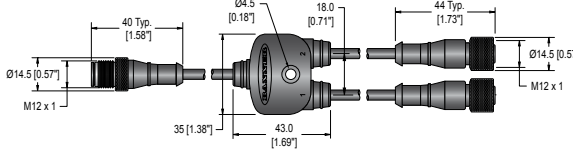
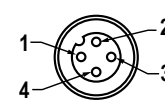
4-Pin Threaded M12/Euro-Style Cordsets—Double Ended				
Model	Length	Style	Dimensions	Pinout
MQDEC-401SS	0.31 m (1 ft)	Male Straight/ Female Straight		
MQDEC-403SS	0.91 m (3 ft)			
MQDEC-406SS	1.83 m (6 ft)			
MQDEC-412SS	3.66 m (12 ft)			
MQDEC-420SS	6.10 m (20 ft)			
MQDEC-430SS	9.14 m (30 ft)			
MQDEC-450SS	15.2 m (50 ft)			

4-Pin Threaded M12/Euro-Style Splitter Cordsets — Flat Junction				
Model	Branches (Female)	Trunk (Male)	Dimensions	Pinout
CSB-M1240M1240	No branch	No trunk		
CSB-M1240M1241	2 x 0.30 m (1 ft)	No trunk		
CSB-M1241M1241		0.30 m (1 ft)		
CSB-M1248M1241		2.50 m (8 ft)		
CSB-M12415M1241		4.57 m (15 ft)		
CSB-M12425M1241		7.60 m (25 ft)		
CSB-UNT425M1241		7.60 m (25 ft) Unterminated		

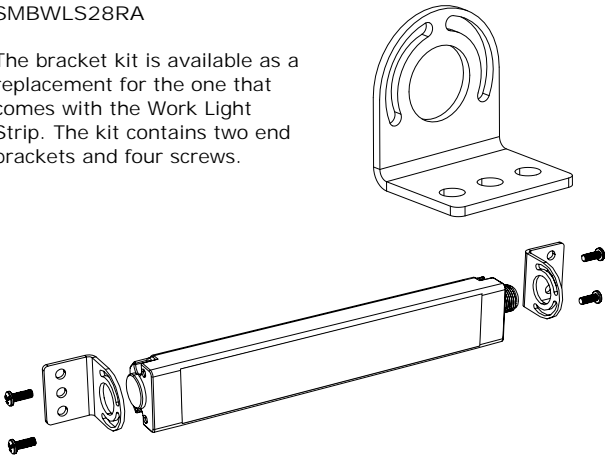
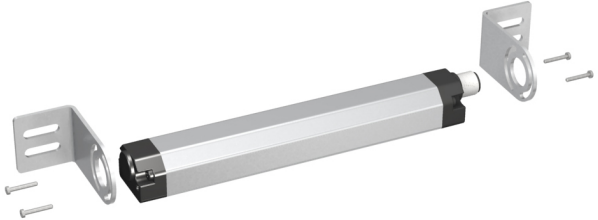
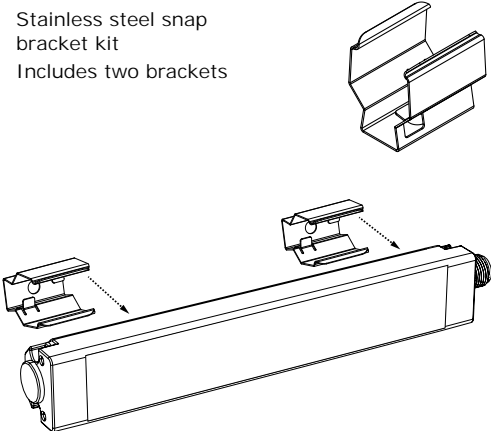
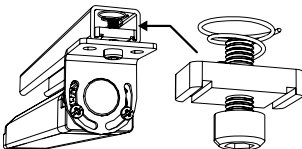
Brackets

<p><b>SMBWLS28RA</b></p> <p>The bracket kit is available as a replacement for the one that comes with the Work Light Strip. The kit contains two end brackets and four screws.</p> 	<p><b>SMBWLS28SM</b></p> <p>This kit allows the light to be mounted at a right angle to the mounting surface. The kit contains two end brackets and four screws.</p> 
<p><b>SMBWLS28SP</b></p> <ul style="list-style-type: none"> <li>• Stainless steel snap bracket kit</li> <li>• Includes two brackets</li> </ul> 	<p><b>SMH1316</b></p> <p>This kit allows the light to be mounted to a 13/16-inch Unistrut channel. The kit includes:</p> <ul style="list-style-type: none"> <li>• #10-32 spring nuts (qty 2)</li> <li>• #10-32 socket head cap screws (qty 2)</li> <li>• #10 lock washers (qty 2)</li> </ul> 
<p><b>SMBWLSMAG</b></p> <p>Magnetic mounting bracket for easy attachment to steel surfaces</p> <p><b>SMBWLSMAGR</b></p> <p>Protective cover also available to prevent scratches to painted surfaces</p> 	

## Banner Engineering Corp Limited Warranty

---

Banner Engineering Corp. warrants its products to be free from defects in material and workmanship for one year following the date of shipment. Banner Engineering Corp. will repair or replace, free of charge, any product of its manufacture which, at the time it is returned to the factory, is found to have been defective during the warranty period. This warranty does not cover damage or liability for misuse, abuse, or the improper application or installation of the Banner product.

THIS LIMITED WARRANTY IS EXCLUSIVE AND IN LIEU OF ALL OTHER WARRANTIES WHETHER EXPRESS OR IMPLIED (INCLUDING, WITHOUT LIMITATION, ANY WARRANTY OF MERCHANTABILITY OR FITNESS FOR A PARTICULAR PURPOSE), AND WHETHER ARISING UNDER COURSE OF PERFORMANCE, COURSE OF DEALING OR TRADE USAGE.

This Warranty is exclusive and limited to repair or, at the discretion of Banner Engineering Corp., replacement. IN NO EVENT SHALL BANNER ENGINEERING CORP. BE LIABLE TO BUYER OR ANY OTHER PERSON OR ENTITY FOR ANY EXTRA COSTS, EXPENSES, LOSSES, LOSS OF PROFITS, OR ANY INCIDENTAL, CONSEQUENTIAL OR SPECIAL DAMAGES RESULTING FROM ANY PRODUCT DEFECT OR FROM THE USE OR INABILITY TO USE THE PRODUCT, WHETHER ARISING IN CONTRACT OR WARRANTY, STATUTE, TORT, STRICT LIABILITY, NEGLIGENCE, OR OTHERWISE.

Banner Engineering Corp. reserves the right to change, modify or improve the design of the product without assuming any obligations or liabilities relating to any product previously manufactured by Banner Engineering Corp.