

Section F Switched Disconnects and Enclosures



Index

Product	Page
Summary	F-2
Ratings Quick Reference Guide	F-3
Labelless Circuit-Lock® Unfused Disconnect Switches	
30, 60 and 100 Amp Units	F-5
Accessories and Replacement Parts	F-6
Dimensions and Specifications	F-7
MotorQuick® Disconnect Switches	
Cost of Ownership Analysis	F-8
Labelless Disconnect Switches and Accessories	F-9
Dimensions and Specifications	F-10
Circuit-Lock® Fused Disconnect Switches	
30 and 60 Amp Units	F-12
Horsepower Ratings and Specifications	F-13
Hazardous Locations	
Unfused Disconnect Switches	F-15
AC Manual Toggle Controllers/Disconnects	
600V AC Manual Motor Controllers/Disconnects	F-17
NEMA 1 Disconnect Switches	F-18
NEMA 3/3R and 3R Disconnect Switches	F-19
30 Ampere, 600 Volts AC Manual Motor Controllers	F-20
40, 50, 60 and 85 Ampere, 600 Volts AC Manual Motor Controllers	F-21
NEMA 4X Disconnect Switches	F-22
Pendant Pushbutton Stations	
CPB2 and PBS Series	F-23
Accessories and Replacement Parts	F-24

Circuit-Lock® Unfused Disconnect Switches



Fused Disconnects, MotorQuick® and VFDs



Hazardous Locations



NEMA 1, 3/3R and 4X Disconnect Switches



Hubbell's Circuit-Lock® Manual Motor Controllers

"Suitable as Motor Disconnects"



Hubbell manufactures one of the most complete lines of motor disconnects on the market. Designed to ensure maximum reliability and performance, Hubbell Circuit-Lock® motor controllers meet or exceed all industry requirements. Because our Circuit-Lock® motor controllers are also disconnects, they ensure safety, compliance, flexibility and productivity for today's industrial and commercial environments. Whether controlling motor loads, safely terminating power or isolating equipment, Hubbell has the solution for you—no matter what the environment or application.



Hubbell Flexibility

With Hubbell's wide range of Circuit-Lock® motor controllers and disconnects that offer several mounting options, NEC® line of sight requirements are easily achieved at the equipment or on the wall in virtually any industrial environment. Switches with a compact footprint, a variety of NEMA® type enclosures and plug-and-play LINKOSITY® make switch placement easier and more flexible than ever.



Hubbell Productivity

Circuit-Lock® keeps assembly lines, goods and services moving. By offering a dual motor controller-disconnect rating, power can be safely terminated at any point in the circuit to perform maintenance on a single motor without shutting down the entire line. With the plug-and-play LINKOSITY® power system, MotorQuick® reduces motor change-out time by more than 65% to get equipment up and running faster.

Hubbell Safety

Safety of personnel and equipment is paramount in any manufacturing environment. Hubbell Circuit-Lock® motor controllers withstand short circuits and provide a high degree of safety across the factory floor. Disconnect Switches for Variable Frequency Drives (VFDs) safely terminate power to prevent risk of injury and damage to high-performance output devices used for controlling today's conveyor systems.



Hubbell Compliance

Compliance with codes and regulations is a must in any industrial environment. Hubbell motor controllers meet a variety of requirements, including OSHA lockout/tagout, NSF certification for hygiene and hazardous location ratings. Each Circuit-Lock® motor controller is UL listed as "Suitable as Motor Disconnect". The NEC® allows for the disconnect and controller to be in one unit.



Variable Frequency Disconnects



Each Controller is Also a Disconnect



NEC® is a registered trademark of the National Fire Protection Association (NFPA).
NEMA® is a registered trademark of the National Electrical Manufacturers Association.



Ratings Quick Reference Guide

Circuit-Lock® Switched Enclosures

Amp	Description	Phase	Poles	HP				Catalog Number
				120	240	480	600	
30	TYPE 1 Non-Metallic	3	3	3	7.5	15	20	HBL1389MQR
	TYPE 1 Non-Metallic	3	3	3	7.5	15	20	HBL1389MQ5
	TYPE 1 Non-Metallic	3	3	3	7.5	15	20	HBL1389MQR2
	NEMA 1 Aluminum	1	2	2	5	10	15	HBL1372D
	NEMA 1 Aluminum	3	3	3	7.5	15	20	HBL1379D
	NEMA 1 Non-Metallic	1	2	2	5	10	15	HBL1392D
	NEMA 1 Non-Metallic	3	3	3	7.5	15	20	HBL1389D
	NEMA 3/3R Non-Metallic	1	2	2	5	10	15	HBL13R22D
	NEMA 3/3R Non-Metallic	3	3	3	7.5	15	20	HBL13R23D
	NEMA 3R Die Cast Aluminum	1	2	2	5	10	15	HBL13R12D
	NEMA 3R Die Cast Aluminum	3	3	3	7.5	15	20	HBL13R13D
	NEMA 3R Aluminum	1	2	2	5	10	15	HBL13R92D
	NEMA 3R Aluminum	3	3	3	7.5	15	20	HBL13R89D
	IP69k TYPE 4X Labelless Non-Metallic	3	3	1	7.5	15	15	HBLDS3
	IP69k TYPE 4X Labelless Non-Metallic	3	3	1	7.5	15	15	HBLDS3AC
	IP69k TYPE 4X Labelless Non-Metallic	3	3	1	7.5	15	15	HBLDS3AC2
	IP69k TYPE 4X Labelless Non-Metallic	3	3	1	7.5	15	15	HBLDS3NK
	IP69k TYPE 4X Labelless Non-Metallic	3	3	1	7.5	15	15	HBLDS3ACNK
	IP69k TYPE 4X Labelless Non-Metallic	3	3	1	5	10	10	HBLDS33ACNK
	TYPE 4X Labelless Non-Metallic	3	3	1	7.5	15	15	HBLDS3MQR
TYPE 4X Labelless Non-Metallic	3	3	1	7.5	15	15	HBLDS3MQ5	
TYPE 4X Labelless Non-Metallic	3	3	1	7.5	15	15	HBLDS3MQR2	
IP69k TYPE 4X Stainless Steel	3	3	1	7.5	15	15	HBLDS3SS	
IP69k TYPE 4X Stainless Steel	3	3	1	7.5	15	15	HBLDS3SSAC	
IP69k TYPE 4X Stainless Steel	3	3	1	7.5	15	15	HBLDS3SSVFD	
TYPE 4X Stainless Steel	3	3	2	7.5	15	15	HBLDS3SSMQR	
TYPE 4X Stainless Steel	3	3	1	7.5	15	15	HBLDS3SSMQ5	
TYPE 4X Non-Metallic Fused Disconnect	3	3	1	7.5	15	20	FDS30	
NEMA 4X Stainless Steel	3	3	3	7.5	15	20	HBL13S33D	
NEMA 4X Non-Metallic	3	3	3	7.5	15	20	HBL13X33D	
60	NEMA 3R Aluminum	1	2	—	10	15	20	HBL16R92D
	NEMA 3R Aluminum	3	3	—	10	25	30	HBL16R93D
	IP69k TYPE 4X Non-Metallic	3	3	7.5	30	50	50	HBLDS6
	IP69k TYPE 4X Non-Metallic	3	3	7.5	30	50	50	HBLDS6AC
	IP69k TYPE 4X Stainless Steel	3	3	7.5	30	50	50	HBLDS6SS
	IP69k TYPE 4X Stainless Steel	3	3	7.5	30	50	50	HBLDS6SSAC
	TYPE 4X Non-Metallic Fused Disconnect	3	3	3	15	30	40	FDS60
	NEMA 4X Stainless Steel	3	3	—	10	25	30	HBL16S63D
NEMA 4X Non-Metallic	3	3	—	10	25	30	HBL16X63D	
100	IP69k TYPE 4X Non-Metallic	3	3	7.5	30	50	50	HBLDS10
	IP69k TYPE 4X Non-Metallic	3	3	7.5	30	50	50	HBLDS10AC
	IP69k TYPE 4X Stainless Steel	3	3	7.5	30	50	50	HBLDS10SS
	IP69k TYPE 4X Stainless Steel	3	3	7.5	30	50	50	HBLDS10SSAC



HBL1379D



HBL1389D



HBLDS3



HBL16R93D



HBL13S33D



FDS30



HBLDS3SS



HBLDS3SSR



HBLDS3MQR



HBLDS3MQ5

Circuit-Lock® Switches

Amp	Description	Phase	Poles	HP				Catalog Number
				120	240	480	600	
30	Toggle Switch	1	2	2	5	10	15	HBL7832D
	Short Toggle Switch	1	2	2	5	10	15	HBL7832DS
	Toggle Switch, Bulk Pack	1	2	2	5	10	15	HBL7832DX
	Toggle Switch	3	3	3	7.5	15	20	HBL7810D
	Short Toggle Switch	3	3	3	7.5	15	20	HBL7810DS
40	Toggle Switch	1	2	2	5	10	15	HBL7842D
	Toggle Switch	3	3	3	7.5	15	20	HBL7843D
50	Toggle Switch	1	2	2	5	10	15	HBL7852D
	Toggle Switch	3	3	3	7.5	15	25	HBL7853D
—	Finger guard (30–50A Switches)	—	—	—	—	—	—	HBLFG30
60	Toggle Switch	1	2	—	10	15	20	HBL7862D
	Toggle Switch	3	3	—	10	25	30	HBL7863D
	Toggle Switch – Front Wire	1	2	—	10	15	20	HBL7862FWD
	Toggle Switch – Front Wire	3	3	—	10	25	30	HBL7863FWD
85	Toggle Switch	1	2	—	10	15	20	HBL7882D
	Toggle Switch	3	3	—	10	25	40	HBL7883D



HBL7810D



HBL7853D



HBL7862D



HBL7863D



Labelless Circuit-Lock® 30, 60, and 100 Ampere Unfused Disconnect Switches

NEC section 430.102(B) requires each motor controller to have a disconnect within line of sight from the motor and driven equipment. NEC section 430.109(A)(6) recognizes that a manual motor controller and disconnect can be the same unit, provided it has been tested for this purpose. Hubbell's Circuit-Lock® Unfused Disconnect Switches are UL listed as a manual motor controller and also "suitable as a motor disconnect" and meet these code requirements. In addition, the enclosure offers the ability to lock directly wired motor loads in the OFF position to comply with OSHA Lockout/Tagout regulations. This safety enclosure is Type 4X (Wash down, Corrosion resistant) IP69k and is also suitable for use with metallic conduit. The switch is mounted on an internal frame that is integral with the enclosure and bonds all grounds, and it accepts auxiliary contacts that can be used to signal PLC controllers.

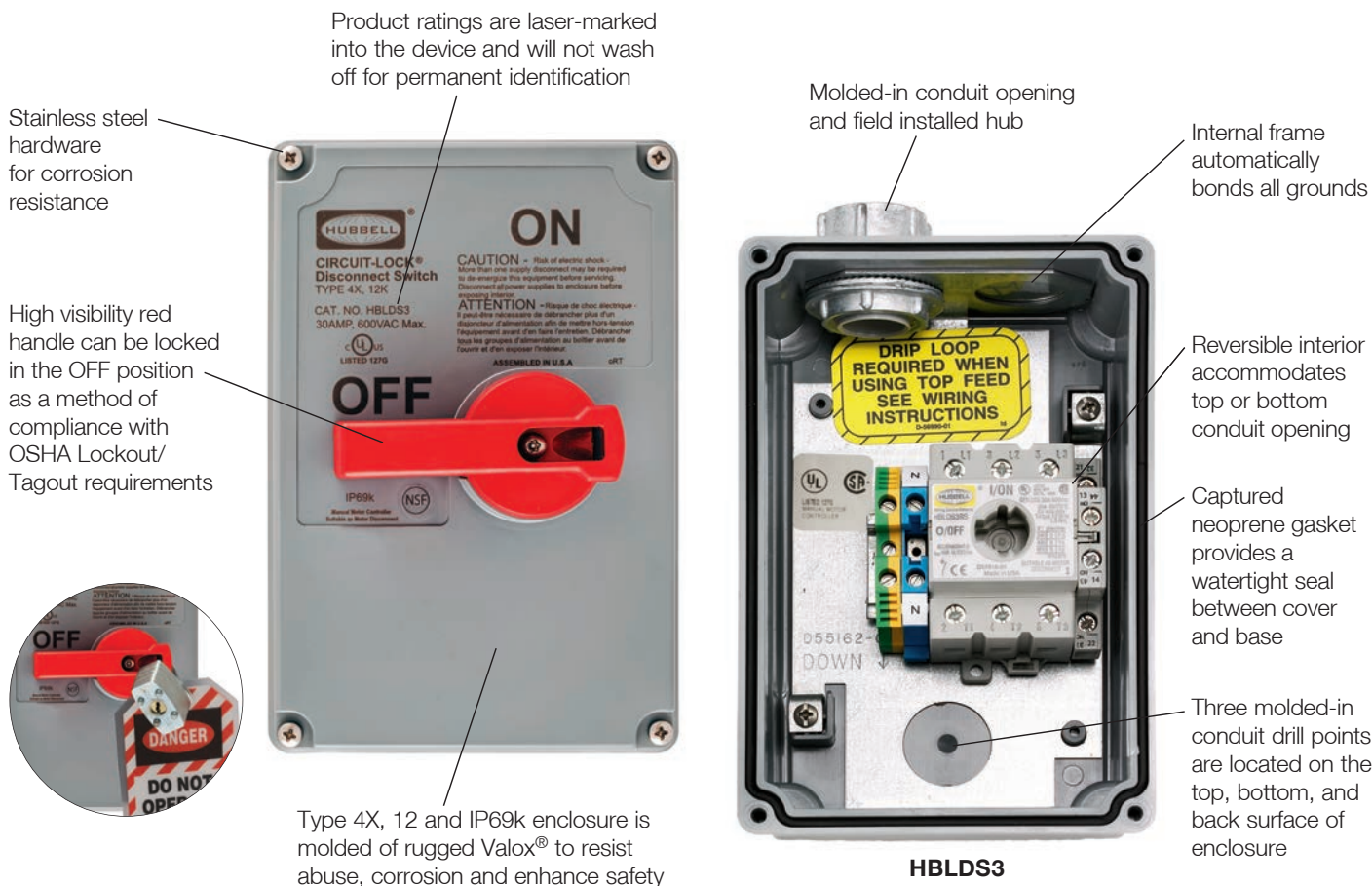

Labelless Circuit-Lock® Unfused Disconnect Switches are available in 30, 60 and 100 Amp, 600V AC ratings.

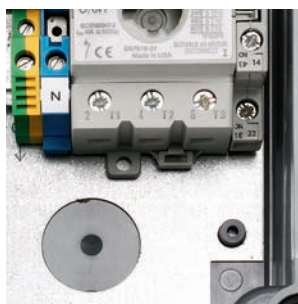

Auxiliary contacts are available for control circuit applications including the ON/OFF control of pilot lights or signal for programmable controllers.



Conduit hub and adjustable mounting feet are supplied for ease of installation.

Valox® is a trademark of SABIC Innovative Plastics, acquired from General Electric Company.

Switched Disconnects and Enclosures

Circuit-Lock® Unfused Disconnect Switches

"Suitable as Motor Disconnects"



Labelless Circuit-Lock® Unfused Disconnect Switches in Non-Metallic Enclosures*

Description	30 Amp	60 Amp	100 Amp
Labelless disconnect switch.	HBLDS3	HBLDS6	HBLDS10
Labelless disconnect switch for use with variable frequency drives.	HBLDS3VFD	HBLDS6VFD	HBLDS10VFD
Labelless disconnect switch with HBLAC1 auxiliary contact.	HBLDS3AC	HBLDS6AC	HBLDS10AC
Labelless disconnect switch with HBLAC2 auxiliary contact.	HBLDS3AC2	—	—
Labelless disconnect switch without conduit knockout or conduit fitting.	HBLDS3NK	—	—
Labelless disconnect switch with HBLAC1 auxiliary contact without conduit knockout or conduit fitting.	HBLDS3ACNK	—	—
Labelless disconnect switch with 3 auxiliary contacts, without conduit knockouts. Break before main break – 1 set "normally open", 1 set "normally closed". Break after main break – 2 sets "normally open", 1 set "normally closed".	HBLDS33ACNK	—	—



HBLDS3AC



HBLDS3SS



HBLDS3SSR

Circuit-Lock® Unfused Disconnect Switches in Stainless Steel Enclosures*

Description	30 Amp	60 Amp	100 Amp
Square Top disconnect switch.	HBLDS3SS	HBLDS6SS	HBLDS10SS
Square Top disconnect switch for use with variable frequency drives.	HBLDS3SSVFD	HBLDS6SSVFD	HBLDS10SSVFD
Square Top disconnect switch with HBLAC1 auxiliary contact.	HBLDS3SSAC	HBLDS6SSAC	HBLDS10SSAC
Sloped Top disconnect switch.	HBLDS3SSR	HBLDS6SSR	HBLDS10SSR
Sloped Top disconnect switch for use with variable frequency drives.	HBLDS3SSRVFD	HBLDS6SSRVFD	HBLDS10SSRVFD
Sloped Top disconnect switch with HBLAC1 auxiliary contact.	HBLDS3SSRAC	HBLDS6SSRAC	HBLDS10SSRAC

Auxiliary Contacts for 30, 60 and 100 Amp Switch, NEMA A600 Pilot Duty

Description	Catalog Number
"Break After Main Break", 1 set of n/o contacts, 1 set of n/c contacts.	HBLAC1**
"Break Before Main Break", 1 set of n/o contacts.	HBLAC2**

Note: *Certified by NSF, International.

**Up to two auxiliary contacts per enclosure. Not for use with HBLDS33ACNK.
30A Units are supplied with one 3/4 in. NPT Raintight conduit fitting.
60A and 100A Units are supplied with two 1 1/4 in. NPT Raintight conduit fittings.



HBLAC1



HBLAC2

Variable Frequency Drive Diagram

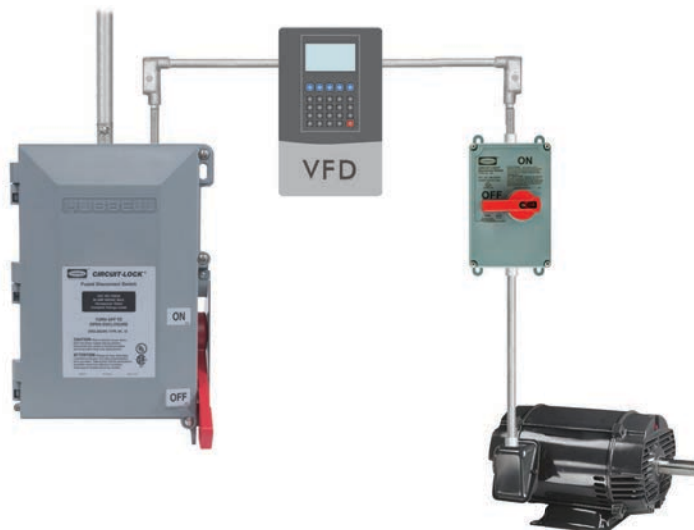



IP66
 SUITABILITY



HBLDS3RC



HBLDS3SSRC



HBLD3SSRRC



HBL30RGB



HBL30RNB



HBLDS3RS



HBLRFT1

Labelless Replacement Covers

Description	30 Amp	60 Amp	100 Amp
For non-metallic switches.	HBLDS3RC	HBLDS6RC	HBLDS10RC
For square top stainless steel switches.	HBLDS3SSRC	HBLDS6SSRC	HBLDS10SSRC
For sloped top stainless steel switches.	HBLD3SSRRC	HBLD60100SSRRC	HBLD60100SSRRC

Replacement Ground Block

Description	Catalog Number
For 30A switches.	HBL30RGB
For 60A and 100A switches.	HBL60100RGB

Replacement Neutral Block

Description	Catalog Number
For 30A switches.	HBL30RNB
For 60A switches.	HBL60RNB
For 100A switches.	HBL100RNB

Replacement Switches

Description	Catalog Number
For 30A switches.	HBLDS3RS
For 60A and 100A switches.	HBLDS60100RS
For HBLDS33ACNK.	HBLDS33ACRS

Replacement Mounting Feet

Description	Catalog Number
For 30A non-metallic switches.	HBLRFT1^Δ
For 60A and 100A non-metallic switches.	HBLRFT2^Δ

Note: ^Δ Package of 10 feet and 10 screws.

Switched Disconnects and Enclosures Circuit-Lock® Unfused Disconnect Switches

Dimensions and Specifications



Dimensions

Key	Labelless Non-Metallic		Stainless Steel, Square Top		Stainless Steel, Sloped Top	
	30A inch (mm)	60A/100A inch (mm)	30A inch (mm)	60A/100A inch (mm)	30A inch (mm)	60A/100A inch (mm)
A	6.00 (152)	7.75 (197)	—	—	—	—
B	5.12 (130)	6.87 (175)	4.87 (124)	7.30 (185)	5.41 (137)	7.66 (195)
C	4.12 (105)	4.75 (121)	3.30 (84)	5.50 (140)	4.50 (114)	6.45 (164)
D	6.62 (168)	8.00 (203)	—	—	—	—
E	7.62 (194)	9.95 (253)	7.05 (179)	10.30 (262)	8.60 (218)	11.41 (290)
F	8.50 (216)	11.00 (279)	8.38 (213)	11.63 (296)	8.22 (209)	11.17 (284)
G	4.12 (105)	5.94 (151)	5.39 (137)	5.93 (151)	4.92 (125)	6.10 (155)

Horsepower Ratings

Voltage	30A	30A*	60A	100A
1Ø 120V AC	1	1	7.5	7.5
1Ø 200–240V AC	3	2.5	15	15
1Ø 480V AC	5	5	30	30
3Ø 200–240V AC	7.5	5	30	30
3Ø 480V AC	15	10	50	50
3Ø 600V AC	15	10	50	50

Note: *HBLDS33ACNK.

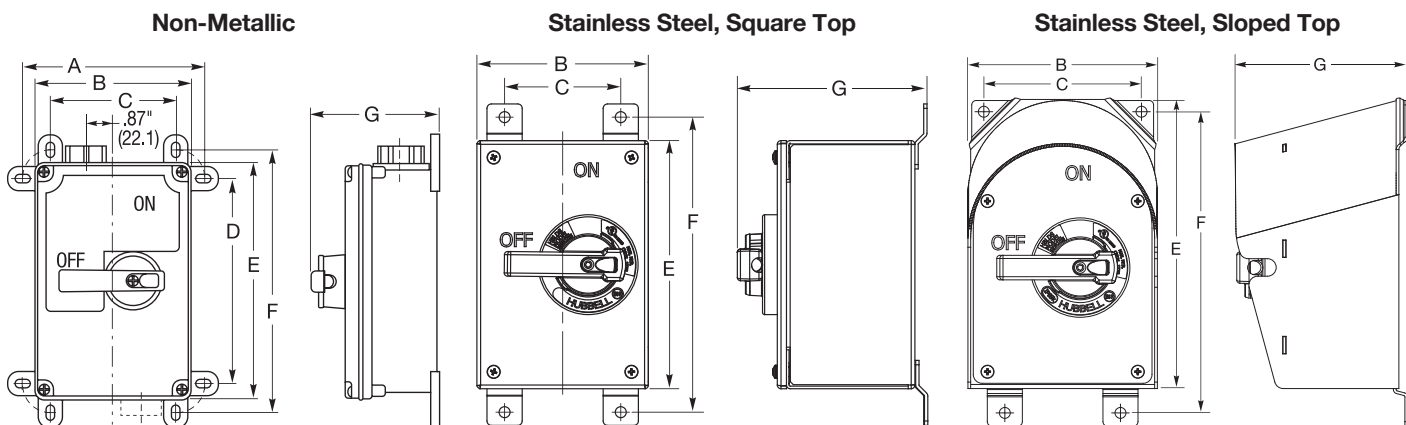

Circuit-Lock® Unfused Disconnect Switches

Specifications

Moisture Resistance

Indoor and Outdoor – Type 4X (Wash down, Corrosion resistant);
Indoor – 30, 60A and 100A Type 12 (Dust-tight, Falling Dirt, Noncorrosive Liquids).

Flammability

UL94-5VA and V0 Classification.

Operating Temperature

Maximum Continuous 75°C; Minimum Continuous -40°C without impact.

UV Resistance

All materials are UV stabilized.

Dielectric Voltage

Withstands 3000V AC minimum.

Max. Working Voltage

600V AC RMS.

Current Interrupting

Certified for current interrupting at full rated current and voltage.

Short Circuit Current Ratings (SCCR):
(Motor Disconnect)

- 30/60/100A: Suitable for use on a circuit capable of delivering not more than 10kA RMS symmetrical, 600V AC max.
- 30A: Suitable for use on a circuit capable of delivering not more than 65kA RMS symmetrical, 600V AC max. when protected by Class J fuses rated 30A max.
- 60/100A: Suitable for use on a circuit capable of delivering not more than 65kA RMS symmetrical, 600V AC max. when protected by Class J fuses rated 100A max.

Terminal Identification

In accordance with UL, CSA and international conventions.

Product Identification

Identification and ratings are part of external label.

Mounting

Non-Metallic - External fully adjustable feet. Stainless Steel - Feet are fixed.

Impact Resistance

In accordance with UL 746C.

Materials

Part	Non-Metallic	Stainless Steel
Base	Valox®	#14 Gauge Type 304 Stainless Steel
Top	Valox®	#14 Gauge Type 304 Stainless Steel
Handle	Valox®	Valox®
Conduit Hub	Zinc 30A Unfused - 3/4 in. Zinc 60/100A Unfused - 1 1/4 in.	Zinc 30A - 3/4 in. Zinc 60/100A - 1 1/4 in.
Enclosure Gasket	Neoprene	Neoprene
Shaft (Unfused)	Valox®	Valox®
Shaft Seal	Molded Neoprene	Molded Neoprene
Frame	Galvanized Steel	N/A
Enclosure Screws	Stainless Steel 300 Series	Stainless Steel

Valox® is a trademark of SABIC Innovative Plastics, acquired from General Electric Company.

Dimensions in Inches (mm)



MotorQuick® significantly reduces the time it takes to replace motors by combining the plug-and-play technology of the LINKOSITY® power system with the versatility of Circuit-Lock® motor disconnect switches. Quick disconnect terminations will reduce motor change-out time by approximately 65%. Keeping spare motors

already pre-wired with a LINKOSITY® inlet enables wiring to be done off-line when it is convenient, not critical. Motor rotation can be pre-checked in a maintenance shop to further speed the installation. The net result is that equipment is up and running in a fraction of the time, helping improve the bottom line.



MotorQuick® Cost of Ownership Analysis

Traditional Motor Changeout

Catalog Number	Total Material Cost	Labor Cost/ Hr	Downtime	Total Labor Cost	Downtime Cost/hr	Total Downtime Cost	Total Cost
HBL1389D	\$106.00	\$53.00	1 hour	\$53.00	\$750.00	\$750.00	\$909.00
HBLDS3	\$185.00	\$53.00	1 hour	\$53.00	\$750.00	\$750.00	\$988.00

MotorQuick® Motor Changeout

Catalog Number	Total Material Cost	Labor Cost/ Hr	Downtime	Total Labor Cost	Downtime Cost/hr	Total Downtime Cost	Total Cost	Total Savings
HBL1389MQ*	\$299.00	\$53.00	20 minutes	\$17.67	\$750.00	\$250.00	\$566.67	\$342.33
HBLDS3MQ*	\$411.00	\$53.00	20 minutes	\$17.67	\$750.00	\$250.00	\$678.67	\$309.33

Note: *MotorQuick catalog numbers are based on the average cost of the various designs.

30 Ampere, 600 Volts AC

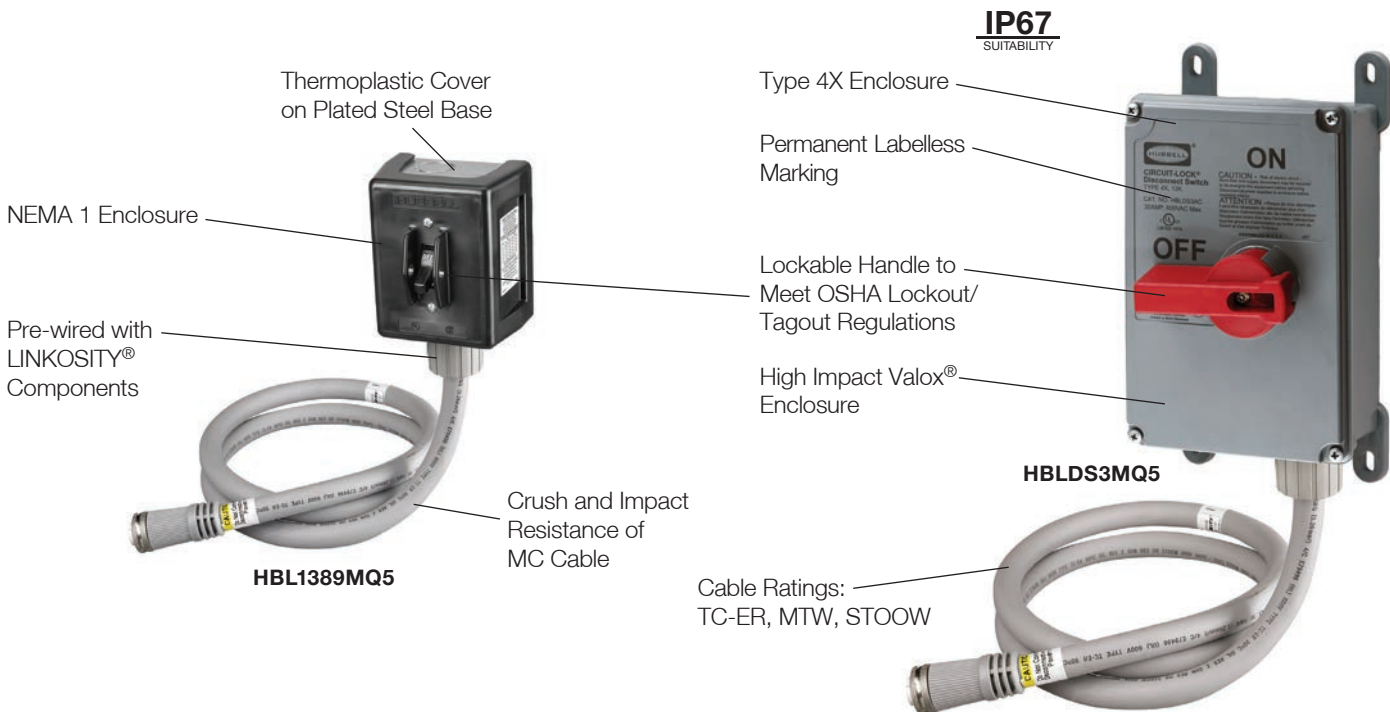

MotorQuick® Disconnect Switches

Type 1 Non-Metallic Enclosure 30A 3 Pole 600V AC	Catalog Number	
HBL1389D with one pre-wired LINKOSITY® female receptacle (load side).	HBL1389MQR	
HBL1389D with 5 foot pre-wired LINKOSITY® female cable (load side).	HBL1389MQ5	
HBL1389D with one pre-wired LINKOSITY® male receptacle (line side) and one pre-wired LINKOSITY® female receptacle (load side).	HBL1389MQR2	
Type 4X Non-Metallic Labelless Enclosure 30A 3 Pole 600V AC	Catalog Number	
HBLDS3 with one pre-wired LINKOSITY® female receptacle (load side).	HBLDS3MQR	
HBLDS3 with 5 foot pre-wired LINKOSITY® female cable (load side).	HBLDS3MQ5	
HBLDS3 with one pre-wired LINKOSITY® male receptacle (line side) and one pre-wired LINKOSITY® female receptacle (load side).	HBLDS3MQR2	
Type 4X Stainless Steel Enclosure 30A 3 Pole 600V AC	Sloped Top	Square Top
HBLDS3SS with one pre-wired LINKOSITY® female receptacle (load side).	HBLDS3SSRMQR	HBLDS3SSMQR
HBLDS3SS with 5 foot pre-wired LINKOSITY® female cable (load side).	HBLDS3SSRMQ5	HBLDS3SSMQ5
HBLDS3SS with one pre-wired LINKOSITY® male receptacle (line side) and one pre-wired LINKOSITY® female receptacle (load side).	HBLDS3SSRMQR2	HBLDS3SSMQR2



Accessories

Description	Catalog Number
3P 4W LINKOSITY® male receptacle for installation on motor.	RM3004PA001
3P 4W LINKOSITY® female receptacle for installation in switch.	RF3004PA001
3P 4W LINKOSITY® double ended (male/female) 5-50 foot cable.	PH3004PAxxx*
3P 4W LINKOSITY® single ended (female) 5-50 foot cable.	PF3004PAxxx*
Cord connector, ¼ in. NPT .63-.75 in. (16.0-19.1) diameter.	SHC1037CR
Lock-on cover for LINKOSITY® connections.	PH2030C

Note: *Cables available from 5-50 feet in 5 foot increments. To purchase larger cable, replace the **xxx** with the required length in feet. (Examples: **PH3004PA005** = 5 foot cable, **PH3004PA050** = 50 foot cable.)

Sample Set Up

(1) **HBLDS3MQR** + (1) **PH3004PAxxx** + (1) **RM3004PA001** = Total Set Up**



Note: ** Retrofit parts available for pre-existing disconnect switch installations. Please consult factory for availability.

Valox® is a trademark of SABIC Innovative Plastics, acquired from General Electric Company.



Dimensions

Type 1

Type 4X

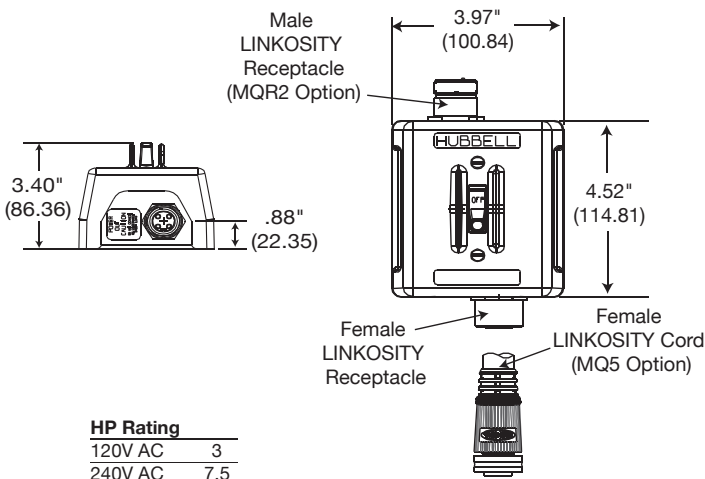

HP Rating	
120V AC	3
240V AC	7.5
480V AC	15
600V AC	20

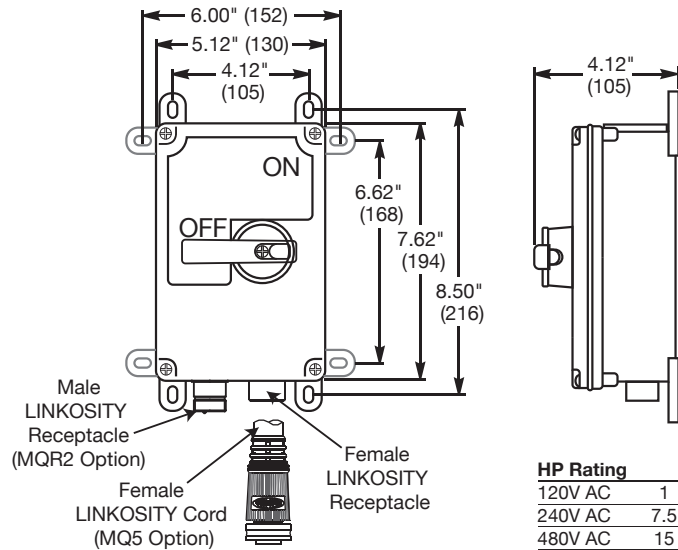

HP Rating	
120V AC	1
240V AC	7.5
480V AC	15
600V AC	15

Specifications

Type 1

Type 4X

Electrical Performance

Dielectric Voltage	2,200V AC minimum for 1 minute.	2,200V AC minimum for 1 minute.
Electrical Life	6,000 cycles with load.	6,000 cycles with load.
Max. Working Voltage	600V AC RMS.	600V AC RMS.
Short Circuit Current Ratings (SCCR): (Motor Disconnect)	10,000 RMS symmetrical amps when tested with 60A max J fuses.	<ul style="list-style-type: none"> • 30: Suitable for use on a circuit capable of delivering not more than 10kA RMS symmetrical, 600V AC max.
Short Circuit Current Ratings (SCCR): (Motor Controller)	10,000 RMS symmetrical amps when tested with 125A RK5 fuses.	<ul style="list-style-type: none"> • 30A: Suitable for use on a circuit capable of delivering not more than 65kA RMS symmetrical, 600V AC max. when protected by Class J fuses rated 30A max.

Mechanical

Mechanical Life	10,000 minimum cycles.	10,000 minimum cycles.
Terminal Accommodations	Amps AWG Min. AWG Max.	Amps AWG Min. AWG Max.
Terminal Torque	30 #14 #10	30 #14 #10
Impact Resistance	30 20 inch pounds	30 20 inch pounds
	— — —	UL746C

Environmental

Flammability	UL94HB/V-0.	UL94-5VA and V0 Classification.
Operating Temp.	Max. continuous 60°C	Max. continuous 75°C
	Min. continuous w/o impact -40°C	Min. continuous -40°C

Listings

UL 508	Industrial Control Equipment File #E36355	Industrial Control Equipment File #E36355
--------	---	---

LINKOSITY® Connection

Certifications

Connecting Components	Listed to UL 2238 and UL 50E.
-----------------------	-------------------------------

Electrical Performance

Voltage	Up to 600V AC.
Amperage	Up to 30A.

Environmental

Connectivity System Components	
Moisture Resistance	UL Type 4, 4X, 12 and 13.
Ingress Protection	IP67 Suitability.
Flammability	UL94HB cables / UL94V-0 receptacles.

Materials

Connectivity System Components	
Contact Carrier	Nylon 6/6, white.
Contact Materials	Pins - brass.
	Sockets - leaded nickel copper w/ stainless steel sleeve.
Contact Plating	Hard gold over palladium/nickel.
Overmold Material	Glass filled polyurethane, gray.
Coupling Hardware	Nickel plated brass.
Cable (16 AWG and Up)	UL 600V Type TC-ER, MTW 90°C or STCOOW 600V 105°C.

Dimensions in Inches (mm)



Circuit-Lock® 30 and 60 Ampere Fused Disconnect Switches

The Circuit-Lock Fused Disconnect Switch provides fused switched control of a directly wired load. The switch cannot be turned ON unless the enclosure cover is closed. The fuses cannot be accessed until the switch is turned OFF. The fuse holder accepts Class "J" fuses. This enclosure is non-metallic and is listed for Outdoor/Indoor (Type 4X Wash down, Corrosion resistant). The handle can be locked in the OFF position to comply with OSHA Lockout/Tagout regulations.

Three molded-in conduit drill points are located on the top, bottom, and back surface of enclosure. Conduit hub provided: 30A 1 inch NPT, 60A 1 1/4 inch NPT

Adjustable mounting feet (4) can be mounted in any of three positions for ease of installation

Stainless steel hardware for corrosion resistance

Safety interlocked fuse access door

Non-metallic enclosure meets UL 50E Type 4X (watertight) 12 (dust-tight) and IP66 suitability requirements. Enclosure is molded of rugged Valox® to resist abuse, corrosion and enhance safety. All external hardware is stainless steel

Removable door for ease of wiring and installation

FDS30

Fused disconnect switches accept Class "J" fuses

Lockable high visibility red handle to meet OSHA Lockout/Tagout

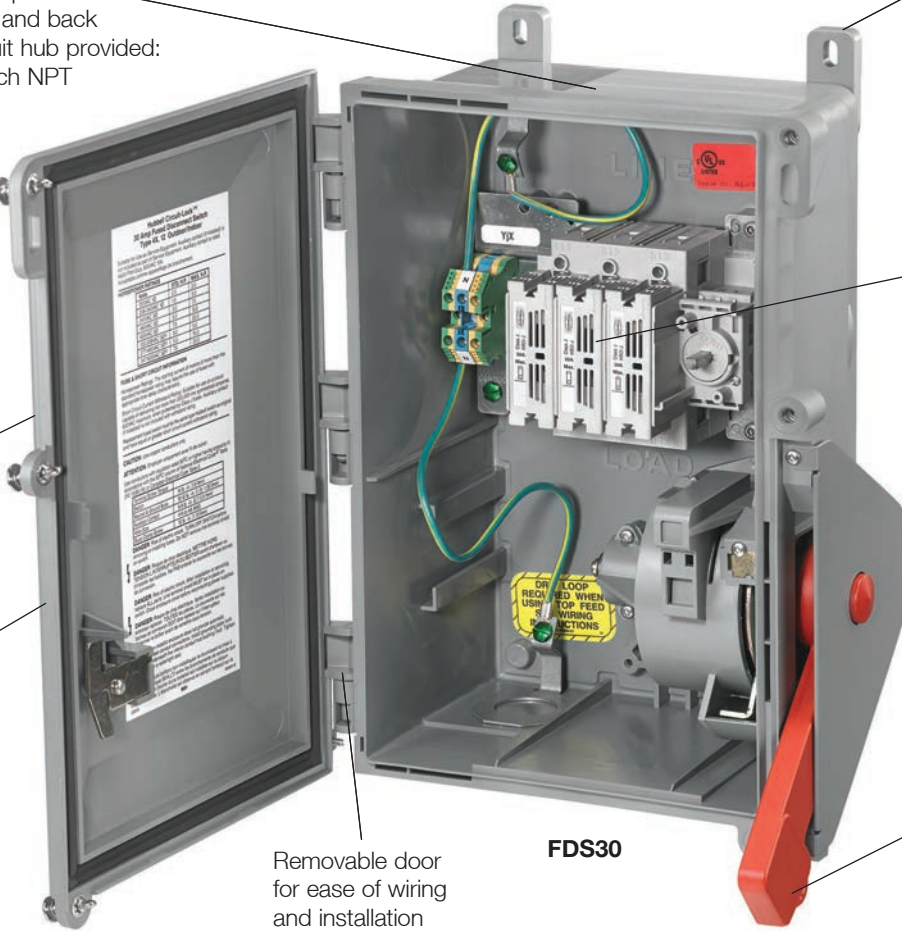

Conduit hub and adjustable mounting feet are supplied with each Circuit-Lock® Fused Disconnect Switch.



Stainless steel 1/4 inch turn door fasteners for quick, easy access to fuses.



Enclosure door can be locked to prevent unauthorized access. Additionally, if the switch is ON, the door cannot be opened.



Compact Fused Disconnect Switch accepts Class "J" fuses. Fuse holders are top mounted for easy access. The switch accepts auxiliary contacts for control circuit applications including the ON/OFF control of remote pilot lights or signal for programmable controllers.

Valox® is a trademark of SABIC Innovative Plastics, acquired from General Electric Company.

IP66
SUITABILITY



FDS30

30 and 60 Amp Fused Disconnect Switches

Description	Catalog Number
30A Circuit-Lock fused disconnect switch.	FDS30*
60A Circuit-Lock fused disconnect switch.	FDS60*

Note: *Class "J" fuses not included.

Auxiliary Contacts

Description	Black Style Switch Catalog Number	Gray Style Switch Catalog Number
Auxiliary contact, normally open, A600 pilot duty, break before break.	ACFSNO	HBLACFSNO
Auxiliary contact, normally closed, A600 pilot duty, break before break.	ACFSNC	HBLACFSNC

Note: Auxiliary contacts are specific to the style switch noted and are NOT interchangeable.

Gray Style Switch



HBLACFSNO HBL30MIFRS

Replacement Switches

Description	Black Style Switch Catalog Number	Gray Style Switch Catalog Number
For 30A fused switches.	30MIFRS	HBL30MIFRS
For 60A fused switches. Gray Style switch will retro fit Black Style switch.	—	HBL60MIFRS

Note: If replacing a Black Style switch, you must use the **30MIFRS**. All other applications can use the Gray Style switch.

Black Style Switch



ACFSNO 30MIFRS

Watertight Closure Plug Kits

Description	Catalog Number
For 30A Circuit-Lock® unfused and fused Pin and Sleeve mechanical interlocks.	MICPK30
For 60 and 100A Circuit-Lock® unfused and fused Pin and Sleeve mechanical interlocks.	MICPK60

Replacement Mounting Feet

Description	Catalog Number
Replacement mounting feet and screws for 30 and 60A fused mechanical interlocks.	HBLRFT2^A

Note: 30A Units supplied with two 1 in. NPT raintight conduit fittings.
60A Units supplied with two 1¼ in. NPT raintight conduit fittings.
^A Package of 10 feet and 10 screws.



MICPK30



HBLRFT2

Dimensions

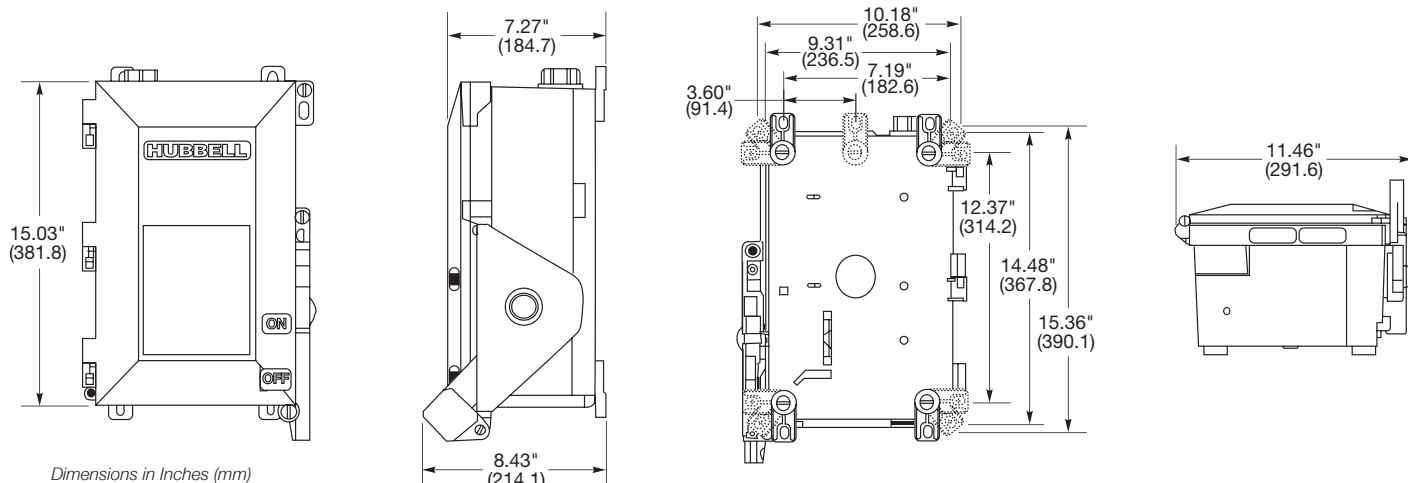

Dimensions in Inches (mm)



Horsepower Ratings

Ratings	Volts	Standard HP	Maximum HP*	Catalog Number
30A	120V AC	0.5	2	FDS30
600V AC	208-240V AC	1.5	3	
Max.	3Ø 240V AC	3	7.5	
	3Ø 480V AC	5	15	
	3Ø 600V AC	7.5	20	
	3Ø Y 120/208V AC	3	5	
	3Ø Y 277/480V AC	5	15	
	3Ø Y 347/600V AC	7.5	20	
60A	120V AC	1.5	3	FDS60
600V AC	208-240V AC	3	7.5	
Max.	3Ø 240V AC	7.5	15	
	3Ø 480V AC	15	30	
	3Ø 600V AC	15	50	
	3Ø Y 120/208V AC	7.5	15	
	3Ø Y 277/480V AC	15	30	
	3Ø Y 347/600V AC	15	40	

Note: *Requires time delay fuses.

Fuse and Short Circuit Information

Horsepower Ratings	The starting current of motors of more than the standard horsepower rating may require the use of fuses with appropriate time-delay characteristics.
Short Circuit Withstand Rating	Suitable for use on a circuit capable of delivering not more than 200,000 RMS symmetrical amperes at the voltage rating of receptacle when protected by Class "J" fuses.

Note: Replacement fused switch must be the same type Hubbell switch as original and have equal or greater short circuit current withstand rating.

Circuit-Lock® Fused Disconnect Switch

Specifications	
Moisture Resistance	Indoor and Outdoor – Type 4X (Wash down, Corrosion resistant); Indoor – Type 12 (Dust-tight, Falling Dirt, Noncorrosive Liquids).
Flammability	UL94-5VA and V0 Classification.
Operating Temperature	Maximum Continuous 75°C; Minimum Continuous -40°C without impact.
UV Resistance	All materials are UV stabilized.
Dielectric Voltage	Withstands 3000V AC minimum.
Max. Working Voltage	600V AC RMS.
Impact Resistance	In accordance with UL 746C.
Terminal Identification	In accordance with UL, CSA and international conventions.
Product Identification	Identification and ratings are part of external label.
Mounting	External fully adjustable feet.
Fuse Types	UL Listed, Class "J"; CSA Certified, HRCI-J.

Materials	
Part	Material
Base	Valox®
Door	Valox®
Handle	Valox®
Conduit Hub	Zinc, 30A Fused – 1 in., 60A Fused – 1¼ in.
Enclosure Gasket	Neoprene
Shaft	Brass
Shaft Seal	Neoprene
Frame	Galvanized Steel
Ground Plate	Galvanized Steel
Enclosure Screws	Stainless Steel 300 Series

Valox® is a trademark of SABIC Innovative Plastics, acquired from General Electric Company.



Hazardous Location Non-Fused Disconnect Switches

Hubbell's hazardous location line of non-fused disconnect switches are typically used for applications with the presence of flammable gasses or vapors, ignitable dusts and fibers. They are also suitable for use in outdoor or indoor damp, wet and dirty locations or in areas where frequent wash downs, heavy rain, or water spray routinely occurs. These switches are compact in size to reduce cost and make it easier to position on the wall or piece of equipment. The enclosures are made of copper-free aluminum and have a polyester/epoxy finish to prevent corrosion. The high visibility handles can be locked out to comply with OSHA lock out/tag out regulations.



Class I, Div. 1 & 2, Groups B,C,D
 Class I, Zones 1 & 2, Groups IIB+ H2, IIA
 Class II, Div. 1 & 2, Groups E,F,G
 Class III, NEMA 3, 4, 4X, 7(B,C,D), 9(E,F,G)

Copper-free aluminum construction with electrostatically applied polyester/epoxy finish to prevent corrosion

Compact NEMA 4X enclosure and footprint allows easy installation in tight locations

- 316 Stainless steel bolts
- Top and bottom drilled and tapped conduit entrances
- For use as motor disconnects



HBLB7NFD13A



Lockable handle to meet OSHA Lockout/Tagout regulations

Large visible rotary handle with "On-Off" indicator allows a quick means of disconnecting power



HBLB7NFD26A

Lockable handle to meet OSHA Lockout/Tagout regulations



Features

- Compact size enclosures provide application flexibility with cost savings over industry standard sizes.
- Fewer cover bolts reduces installation and maintenance time.
- Gasketed flange with O-ring located inside bolt circle to seal out moisture.
- Rotary handle style operating mechanism with lockout provision as standard.
- Removable ductile mounting lugs adjust to irregular mounting surfaces.
- Bodies have top and bottom drilled and tapped conduit entrances for power connection.
- UL98 certified switch.

Applications

- Grain manufacturing and storage
- Industrial chemical and gas manufacturing
- Petroleum refining
- Fertilizer manufacturing
- Vehicle repair/paint shops
- Coal mining
- Cotton and fabric mills



Standard Materials/Finish

- Enclosures: Copper-free aluminum (less than 4/10 of 1% copper content)
- Cover Bolts: 316 Stainless Steel
- O-Ring Gasket: Silicone
- Finish: Grey Powder Polyester painted exterior, electrostatically applied
- Ratings: 600V AC, 230V DC 30–100 Amp

30, 60 and 100 Amp Unfused Hazardous Location Disconnect Switches

Description	Catalog Number
30A 3 Pole disconnect switch.	HBLB7NFD13A
30A 3 Pole disconnect switch with auxiliary contact.	HBLB7NFD13AA
60A 3 Pole disconnect switch.	HBLB7NFD26A
60A 3 Pole disconnect switch with auxiliary contact.	HBLB7NFD26AA
100A 3 Pole disconnect switch.	HBLB7NFD21A
100A 3 Pole disconnect switch with auxiliary contact.	HBLB7NFD21AA



HBLB7NFD13A



HBLB7NFD26A



HBLB7NFD21A



HBLVP3485

Unfused Mechanical Interlocks and Plugs

Amp	Poles/Wires	Voltage AC	Receptacle	Plug
30	3 Pole, 2 Wire	600V AC	HBLVSQ3023	HBLVP3385
	4 Pole, 3 Wire	600V AC	HBLVSQ3034	HBLVP3485
60	3 Pole, 2 Wire	600V AC	HBLVSQ6023	HBLVP6385
	4 Pole, 3 Wire	600V AC	HBLVSQ6034	HBLVP6485

Note: HBLVSQ 30 amp models come standard with 1" drilled and tapped conduit openings top and bottom plus two 1" x 3/4" reducers and one 3/4" close-up plug for maximum flexibility. 60 amp models come with one 1 1/2" opening on top and bottom and one 1 1/2" close-up plug.

Horsepower Ratings

Switch Amps/Phase	Single Phase HP			Three Phase HP			DC HP	Terminal Wire Size	Conduit Sizes	Catalog Number
	120V AC	230V AC	208V AC	230V AC	480V AC	600V AC	230V DC			
30A / 3P	2	5	10	10	20	30	1	#14-10	1 NPT	HBLB7NFD13A
60A / 3P	3	7.5	20	20	40	40	10	#14-4	1 1/2 NPT	HBLB7NFD26A
100A / 3P	5	15	25	30	50	50	20	#8-1	1 1/2 NPT	HBLB7NFD21A

Dimensions

	Outside Box			Inside Box				Mounting Dimensions			
	A	B	C	D	E	F	G	H	I	J	K
30 Amp	5 3/4	8 1/16	6 5/16	3 5/8	5 19/16	5 1/16	3 1/8	8 1/8	–	–	1 1/4
60 & 100 Amp	8 1/8	13 1/16	7 13/16	4 1/4	9 9/16	6 5/16	2 1/2	11 3/8	6 3/8	7 1/2	1 13/16

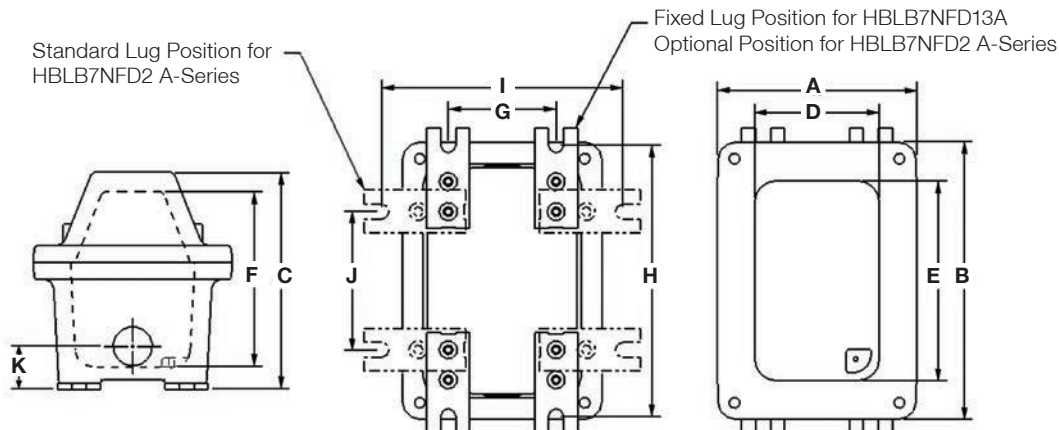

Dimensions in Inches (mm)

Switched Disconnects and Enclosures AC Manual Toggle Controllers/Disconnects

30, 40, 50, 60 and 85A 600V AC



Circuit-Lock® controllers rated "Suitable as Motor Disconnect"

The most complete offering of controllers with top horsepower and high amperage ratings in such a compact device.



30A, 40A and 50A

#10 Brass Terminal Screw

Clamping plate for secure back or side wiring (30A only)

Optional Side Guard

For close wall applications and finger safe environments



Shared Features

Strong on/off action with quick-make, slow break operation

- Provides long-life reliability
- 10,000 Amp High Fault Short Circuit Withstand Rating

Thermoset Body

- Provides high resistance to electrical arc tracking
- Withstands high temperatures
- Excellent dimensional stability
- Superior dielectric strength

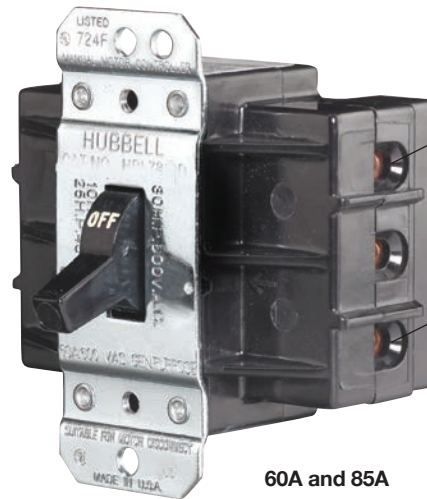

60A and 85A

Front and Back Wiring

Steel Screws and Copper Terminals

Recessed Wiring Wells

Finger safe environments



Optional Side Finger Guards

For close wall applications and finger safe environments. For 30A, 40A and 50A controllers.



Four Large Silver Alloy Contacts per Pole

- Excellent conductivity
- Maximum longevity

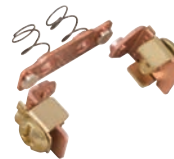

100% Copper Contact Arm

- High heat management
- Reliability



Lubrication-Free Controller

- Continued on/off cycling even in harsh, dust and high heat environments

Switched Disconnects and Enclosures AC Manual Toggle Controllers/Disconnects

30, 40, 50, 60 and 85A 600V AC



600V AC Manual Motor Controllers/Disconnects

For use in almost any industrial environment. Ideal component switch for motor control and as a disconnect. Toggle controllers can be built into equipment and enclosures for either box or panel-mount installation.

Amp	Poles	ToggleType	Wire	HP Rating				Catalog Number
				120V AC 1Ø	240V AC 3Ø	480V AC 3Ø	600V AC 3Ø	
30	2	Standard	Back/Side	2	5	10	15	HBL7832D
	2	Short	Back/Side	2	5	10	15	HBL7832DS
	2	Standard	Back/Side	2	5	10	15	HBL7832DX
	3	Standard	Back/Side	3	7.5	15	20	HBL7810D
	3	Short	Back/Side	3	7.5	15	20	HBL7810DS
40	2	Standard	Side	2	5	10	15	HBL7842D
	3	Standard	Side	3	7.5	15	20	HBL7843D
50	2	Standard	Side	2	5	10	15	HBL7852D
	3	Standard	Side	3	7.5	15	25	HBL7853D
60	2	Standard	Back	—	10	15	20	HBL7862D
	3	Standard	Back	—	10	25	30	HBL7863D
	2	Standard	Front	—	10	15	20	HBL7862FWD
	3	Standard	Front	—	10	25	30	HBL7863FWD
85	2	Standard	Back	—	10	15	20	HBL7882D
	3	Standard	Back	—	10	25	40	HBL7883D
Optional Side Guard, for close wall applications and finger safe environments.								HBLFG30*

Note: *For 30A, 40A and 50A controllers.



HBL7810D



HBL7853D



HBL7863D



HBLFG30

Specifications

Electrical Performance		
Dielectric Voltage	Min. 2,200V AC minimum for 1 minute	
Electrical Life	Min. 6,000 Cycles at rated switch load	
Max. Working Voltage	600V AC RMS	
Short Circuit	Switches	10,000 RMS
Withstand Rating as Motor Disconnect	30A & 40A	60A max. when protected by J fuses
Short Circuit	50A	50A max. when protected by J fuses
Withstand Rating as Motor Controller	60A & 85A	80A max. when protected by J fuses
Short Circuit	All Switches	125A max. RK5 fuses
Withstand Rating as Motor Controller		
Mechanical		
Mechanical Life	Min. 10,000 minimum cycles	
Terminal	Switch Rating	AWG Max.
Accommodations	30A	#10
	40A & 50A	#8**
	60A & 85A	#4
Wire Type	Solid and stranded copper wire only.	
Terminal Torque	30A – 50A	20 inch pounds
Switch Rating	60A – 85A	25 inch pounds
Environmental		
Flammability	UL94HB/VO	
Operating Temp.	Max. 75°C	
	Min. -40°C continuous without impact	
Listings		
	Industrial Control File	
UL 508	#E70402	
CSA-C22.2 No.14	LR-46186	

Note: **Use listed certified ring terminal.

Dimensions

30, 40 and 50 Amp Standard Toggles

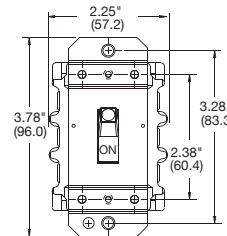

Front

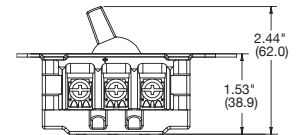

Side

60 and 85 Amp Standard Toggles

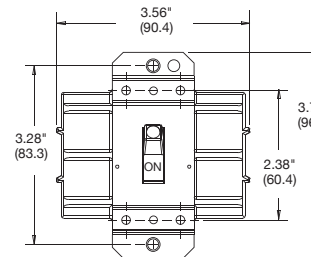

Front

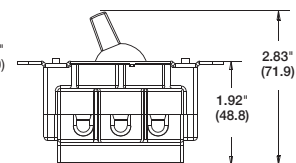

Side

Dimensions in Inches (mm)



HBL1389D

Thermoplastic Cover on a Plated Steel Base
Durable, non-conductive cover



HBL1379D

All Aluminum Cover and Base
Base is pre-drilled for rear surface mounting

Shared Features

Wiring conduit knockouts

- 1/2" and 3/4" NPT
- Top, bottom or back wire entry points

Surface mount control

Switch can be locked in the off position as a method of compliance with OSHA lockout/tagout

Circuit-Lock® NEMA 1 Enclosures with Switch

Ideal for use in industrial environments, i.e. conveyer systems, industrial fans, etc.

Amp	Poles	Enclosure Material	HP Rating				Catalog Number
			120V AC 1Ø	240V AC 3Ø	480V AC 3Ø	600V AC 3Ø	
30	2	Thermoplastic	2	5	10	15	HBL1392D
30	3	Thermoplastic	3	7.5	15	20	HBL1389D
30	2	Aluminum	2	5	10	15	HBL1372D
30	3	Aluminum	3	7.5	15	20	HBL1379D

Note: See page F-17 for technical information.



HBL1389D



HBL1379D

Circuit-Lock® NEMA 1 Enclosures without Switch

For use with switches shown on page F-17.

Description	Cover Material	Base Material	No. Equipment Grounds	Catalog Number
For use with 30A switch.	Thermoplastic	Steel	1	HBL1390
For use with 30A switch.	Aluminum	Aluminum	2	HBL1370



HBL1390



HBL1370

Dimensions

HBL1370, HBL1372D and HBL1379D

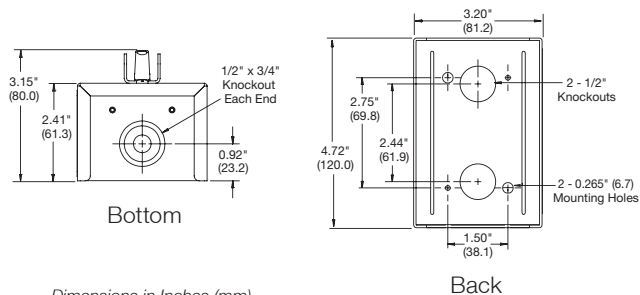

Dimensions in Inches (mm)

HBL1390, HBL1389D and HBL1392D

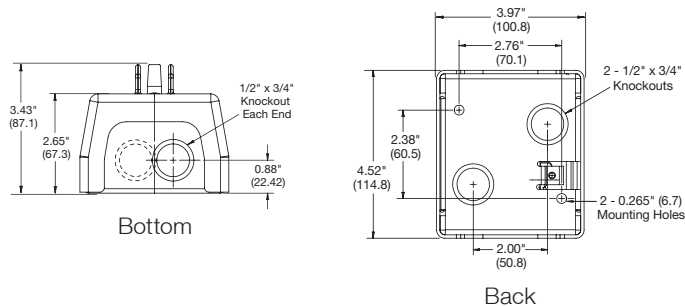

Switched Disconnects and Enclosures NEMA 3/3R and 3R Disconnect Switches

"Suitable as Motor Disconnects"



Circuit-Lock® NEMA 3/3R Enclosures with Switch

Ideal for use on outdoor equipment.

Amp	Poles	Enclosure Material	HP Rating				Catalog Number
			120V AC 1Ø	240V AC 3Ø	480V AC 3Ø	600V AC 3Ø	
30	2	Thermoplastic	2	5	10	15	HBL13R22D
30	3	Thermoplastic	3	7.5	15	20	HBL13R23D
30	2	Aluminum	2	5	10	15	HBL13R12D†
30	3	Aluminum	3	7.5	15	20	HBL13R13D†

Note: See page F-17 for technical information.

*Drill weephole to alter from NEMA 3 to NEMA 3R.

†Equipped with HBLFG30 sidewall insulation barriers.

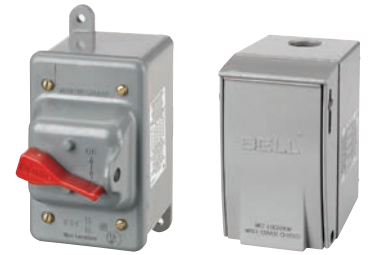

HBL13R23D

HBL13R13D

Dimensions

HBL13R22D and HBL13R23D

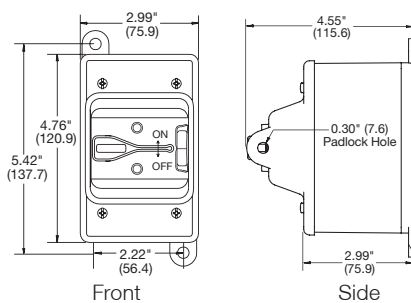

HBL13R12D and HBL13R13D

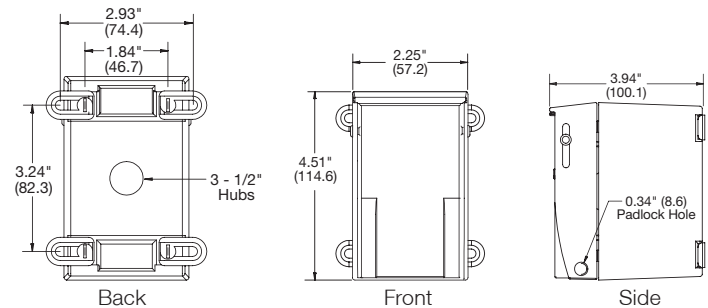

Circuit-Lock® NEMA 3R Enclosures with Switch

Ideal for use in outdoor environments.

Amp	Poles	Enclosure Material	HP Rating				Catalog Number
			120V AC 1Ø	240V AC 3Ø	480V AC 3Ø	600V AC 3Ø	
30	2	Aluminum	2	5	10	15	HBL13R92D
30	3	Aluminum	3	7.5	15	20	HBL13R89D
60	2	Aluminum	—	10	15	20	HBL16R92D
60	3	Aluminum	—	10	25	30	HBL16R93D

Note: For switch specifications refer to page F-17.



HBL13R89D

HBL16R93D

Circuit-Lock® NEMA 3R Enclosures without Switch

For use with switches shown on page F-17.

Description	Enclosure Material	Catalog Number
For use with 30A switch.	Aluminum	HBL13R90
For use with 60A switch.	Aluminum	HBL16R90

Dimensions

HBL13R90, HBL13R89D and HBL13R92D

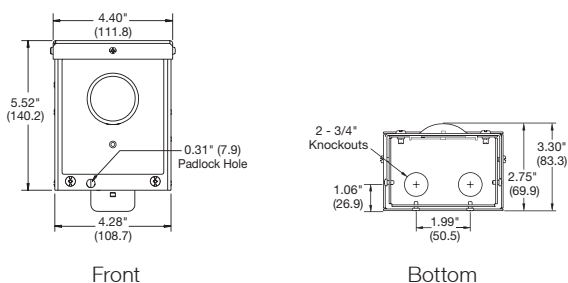

HBL16R90, HBL16R92D and HBL16R93D

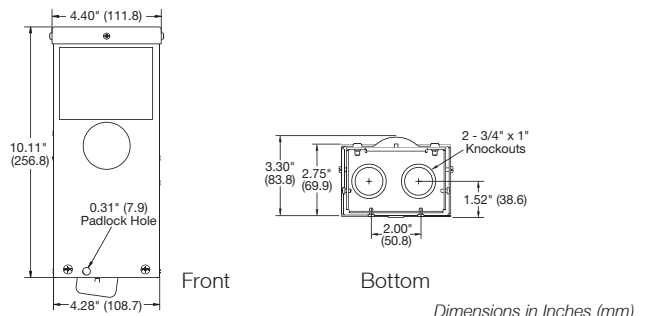

Dimensions in Inches (mm)

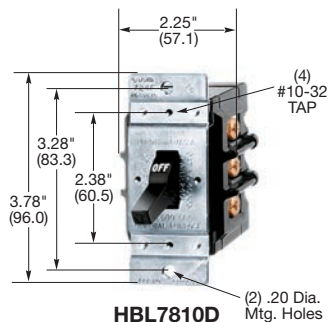

30A 600V AC Manual Motor Controllers, Double Pole

Description	Catalog Number
30A, double pole, single throw, AC manual motor controller, black nylon handle, side and back wired.	HBL7832D
30A, double pole, single throw, AC manual motor controller, black nylon handle, short toggle.	HBL7832DS
30A, double pole, single throw, AC manual motor controller. 50 piece bulk pack.	HBL7832DX
HBL7832D in HBL1390 Type 1 enclosure with non-metallic cover, ½ in. and ¾ in. knockouts on top, bottom and back of steel frame.	HBL1392D
HBL7832D in HBL1370 metal Type 1 enclosure.	HBL1372D
HBL7832D in NEMA 3R non-metallic enclosure.	HBL13R22D
HBL7832D in HBL13R90 metal Type 3R enclosure.	HBL13R92D
HBL7832D in NEMA 3R flip-lid enclosure.	HBL13R12D

Note: See page F-17 for technical information.

30A 600V AC Manual Motor Controllers, Three Pole

Description	Catalog Number
30A, three pole, single throw, AC manual motor controller, black nylon handle, side and back wired.	HBL7810D
30A, three pole, single throw, AC manual motor controller, black nylon handle, short toggle.	HBL7810DS
HBL7810D in HBL1390 Type 1 enclosure with non-metallic cover, ½ in. and ¾ in. knockouts on top, bottom and back of steel frame.	HBL1389D
HBL7810D in HBL1370 metal Type 1 enclosure.	HBL1379D
HBL7810D in NEMA 3R non-metallic enclosure.	HBL13R23D
HBL7810D in HBL13R90 metal Type 3R enclosure.	HBL13R89D
HBL7810D in NEMA 3R flip-lid enclosure.	HBL13R13D
30A, 600V, three pole, rotary controller in NEMA 4X stainless steel enclosure.	HBL13S33D
30A, 600V, three pole, rotary controller in NEMA 4X non-metallic enclosure.	HBL13X33D

Note: See page F-17 for technical information.

Motor Rating

Product	120V AC	240V AC	480V AC	600V AC	Phase
30A Double Pole	2HP	5HP	10HP	15HP	1
30A Three Pole	3HP	7½HP	15HP	20HP	3
40A Double Pole	2HP	5HP	10HP	15HP	1
40A Three Pole	3HP	7½HP	15HP	20HP	3
50A Double Pole	2HP	5HP	10HP	15HP	1
50A Three Pole	3HP	7½HP	15HP	25HP	3
60A Double Pole	-	10HP	15HP	20HP	1
60A Three Pole	-	10HP	25HP	30HP	3
85A Double Pole	-	10HP	15HP	20HP	1
85A Three Pole	-	10HP	25HP	40HP	3

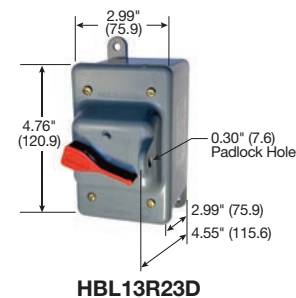
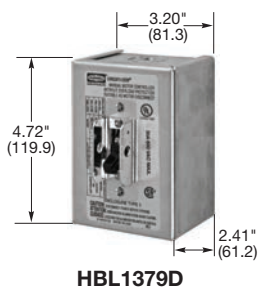

Dimensions in Inches (mm)



IP44*
SUITABILITY

40A 600V AC Manual Motor Controllers

Description	Catalog Number
40A, double pole, single throw, AC manual motor controller, black nylon handle, side wired.	HBL7842D
40A, three pole, single throw, AC manual motor controller, black nylon handle, side wired.	HBL7843D

Note: See page F-17 for technical information.

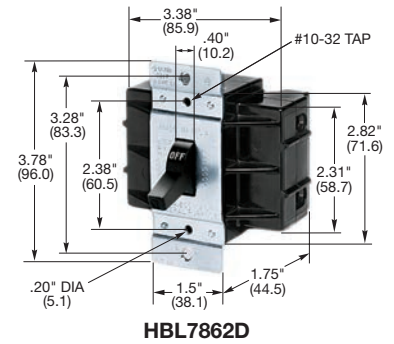

50A 600V AC Manual Motor Controllers

Description	Catalog Number
50A, double pole, single throw, AC manual motor controller, black nylon handle, side wired.	HBL7852D
50A, three pole, single throw, AC manual motor controller, black nylon handle, side wired.	HBL7853D

Note: See page F-17 for technical information.

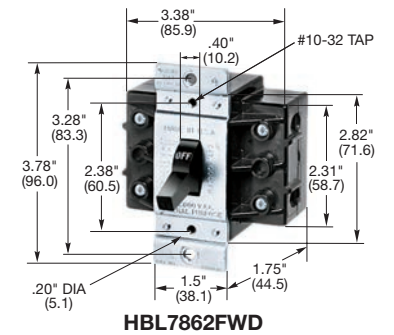

60A 600V AC Manual Motor Controllers

Description	Catalog Number
60A, double pole, single throw, AC manual motor controller, black nylon handle, back wired.	HBL7862D
Same as HBL7862D except front wired.	HBL7862FWD
HBL7862FWD in Type 3R enclosure.	HBL16R92D
60A, three pole, single throw, AC manual motor controller, black nylon handle, back wired.	HBL7863D
Same as HBL7863D except front wired.	HBL7863FWD
HBL7863FWD in a Type 3R enclosure.	HBL16R93D
60A, 600V, three pole, rotary controller in NEMA 4X stainless steel enclosure.	HBL16S63D
60A, 600V, three pole, rotary controller in NEMA 4X non-metallic enclosure.	HBL16X63D

Note: See page F-17 for technical information.

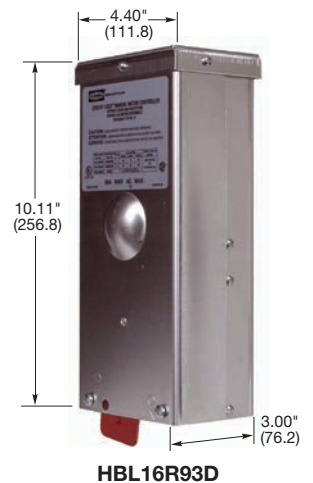

85A 600V AC Manual Motor Controllers

Description	Catalog Number
85A, double pole, single throw, AC manual motor controller, black nylon handle, back wired.	HBL7882D
85A, three pole, single throw, AC manual motor controller, black nylon handle, back wired.	HBL7883D

Note: See page F-17 for technical information.

Motor Controller Accessories

Description	Catalog Number
Finger Guards, fit 30A, 40A and 50A controllers.	HBLFG30
Auxiliary Contacts, NO/Common/NC, for use in rotary switches only.	HBLAUX



Dimensions in Inches (mm)



Shared Features

Un-drilled case allows custom placement of wire entry

Switch can be locked in the off position as a method of compliance with OSHA lockout/tagout

Hinged Cover with Removable Continuous Pin

304 Stainless Steel Enclosure
Chemical and corrosion resistant

Valox® Handle and Collar
Chemical and impact resistant

Thermoplastic 4X Non-Metallic Enclosures



HBL13S33D

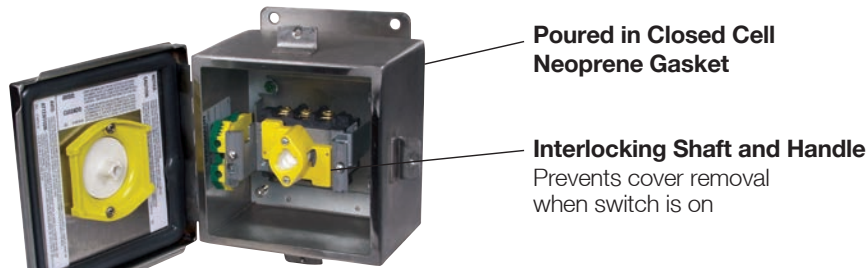

Poured in Closed Cell Neoprene Gasket

Interlocking Shaft and Handle
Prevents cover removal when switch is on

Up to 2 Optional Auxiliary Contacts
For PLCs and external indicators



HBL13X33D

Circuit-Lock® NEMA 4X Enclosures with Switch and Accessories

Ideal for use in environments where wash-down is necessary, i.e. food processing, laboratories, etc.



HBL16S63D

HBL13X33D

Amp	Poles	Enclosure Material	HP Rating				Catalog Number
			120V AC 1Ø	240V AC 3Ø	480V AC 3Ø	600V AC 3Ø	
30	2	Stainless Steel	3	7.5	15	20	HBL13S33D
30	3	Valox	3	7.5	15	20	HBL13X33D
60	3	Stainless Steel	—	10	25	30	HBL16S63D
60	3	Valox	—	10	25	30	HBL16X63D

Finger Guard option for 30A switch. **HBLFG30**

NO/Common/NC auxiliary contact, 10A 120/250V AC for 30 and 60 Amp switches. **HBLAUX**

Note: See page F-17 for technical information.

Dimensions

HBL13S33D

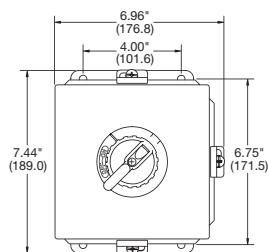

Front

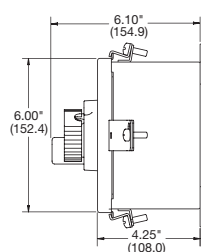

Side

HBL16S63D

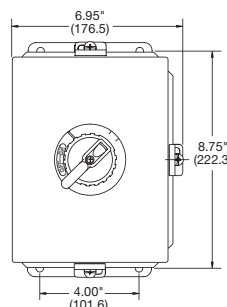

Front

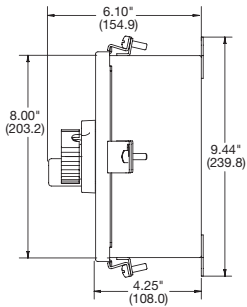

Side

Dimensions in Inches (mm)

Valox® is a trademark of SABIC Innovative Plastics, acquired from General Electric Company.



IP55
SUITABILITY

CPB Series Compact Pendant Stations, Two Button, NEMA 4X

Description	Catalog Number
Single-speed normally open-normally closed without mechanical interlock.	CPB20
Single-speed with mechanical interlock between pushbuttons.	CPB21
Two-speed with mechanical interlock between pushbuttons.	CPB22

Note: Included with product: nylon cord grip and sealing washer (must be installed to achieve NEMA 4X rating).
 Indication label pack. Cord dia. range .375-.625 in. (9.5-15.9)
 Ambient temperatures: 25°F to 140°F (32°C to 60°C).
 Typical applications: Package electric motor hoists. Remote control of machinery.

Contact Ratings, CPB Series

Single-Speed	Voltage	Current
AC	120V	6A
35% PF	240V	3A
DC	125V	1.1A
IND	250V	.55A
Two-Speed	Voltage	Current
AC	120V	3A
35% PF	240V	1.5A



CPB21

Wiring Diagram CPB2 Series

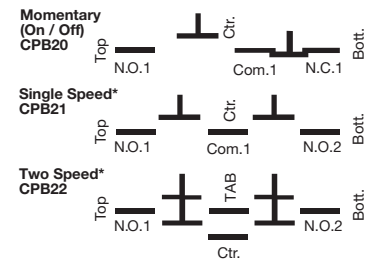

*Mechanical "floating ball" interlock prevents activating both Pushbuttons simultaneously.

IP44
SUITABILITY

PBS Series Heavy Duty Pendant Pushbutton Stations, NEMA 3R

Description	Catalog Number
2 button, single speed.	PBS2
2 button, two speed.	PBS22
4 button, single speed.	PBS4
4 button, two speed.	PBS42
6 button, single speed.	PBS6
6 button, two speed.	PBS62
8 button, single speed.	PBS8
8 button, two speed.	PBS82

Product Dimensions, PBS Series

Style	A	Approx. Wt. Assembled	Catalog Number
2 button	7.88" (200.0)	2.5 lbs	PBS2
4 button	13.69" (347.6)	4.5 lbs	PBS4
6 button	18.0" (457.2)	5.5 lbs	PBS6
8 button	22.31" (566.7)	7.5 lbs	PBS8

Note: Housing: Yellow vinyl rubber.

Contact Interrupting Ratings, PBS Series

Two-Speed Single Break	Voltage	Current
AC	120V	6A
35% PF	240V	3A
DC	125V	.4A
IND	250V	.2A
Single-Speed Double Break	Voltage	Current
AC	120V	6A
35% PF	240V	3A
DC	125V	1.1A
IND	250V	.55A



PBS6

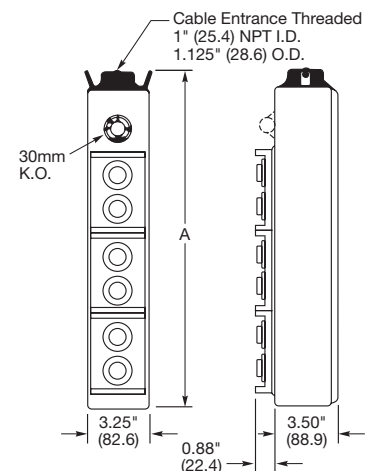

Dimensions in Inches (mm)

**PG2****PG6****MS2****MS5****TB2****TB5****PBSLP****PBSBC****PBSPL1****07401023**

Replacement Inserts

When the insert switches are in need of replacement, simply unplug the old insert and plug in a new one.

Description	Catalog Number
Single speed insert momentary N.O. and N.C.	PG2
On-Off insert (no mechanical interlock). Momentary, start-stop, reset-stop.	PG6
2 or 3 speed insert, momentary. Used to a maximum of 3 speed points.	MS2
5 speed insert, momentary. Used to a maximum of 5 speed points. For five speed applications replace an existing terminal board with the TB5 terminal board and replace an existing insert with the five speed (MS5) insert.	MS5

Conversion Inserts

In addition to single speed and two speed applications, pre-assembled units can be adapted to handle other applications.

Description	Catalog Number
Terminal board, required for each insert switch PG2, PG6 and MS2.	TB2
Terminal board, required for insert switch MS5.	TB5

Accessories

Description	Catalog Number
Indicator labels for replacement package contains 1 each: hoist, trolley, bridge, forward-reverse, raise-lower, in-out, right left, east-west, north-south, reset-stop, start-stop, power, main hoist, auxiliary hoist, on-off, up-down.	PBSLP
Rubber button cover for replacement purposes.	PBSBC
120V red pilot light for 4, 6, and 8 button units only.	PBSPL1*

Note: *Each pendant station can accommodate one of the pilot light in the 1.20 in. (30.6) diameter mounting hole.

Kellems® Deluxe Aluminum Cord Fitting

Outdoor or indoors where subject to moisture, splash or submersion. Kellems grips provide strain relief for multi-conductor cable.

Description	Cord Range	Catalog Number
Kellems grip.	.750"-.875" (19-22.2)	07401023
Kellems grip.	.875"-1.00" (22.2-25.4)	07401025