

**PSEN enc m1 eCAM, PSEN enc m2 eCAM
PSEN enc s1 eCAM, PSEN enc s2 eCAM**

pilz

Position Monitoring

This document is a translation of the original document.

All rights to this documentation are reserved by Pilz GmbH & Co. KG. Copies may be made for internal purposes.

Suggestions and comments for improving this documentation will be gratefully received.

Pilz[®], PIT[®], PMI[®], PNOZ[®], Primo[®], PSEN[®], PSS[®], PVIS[®], SafetyBUS p[®], SafetyEYE[®], SafetyNET p[®], the spirit of safety[®] are registered and protected trademarks of Pilz GmbH & Co. KG in some countries.



SD means Secure Digital.

Contents

Contents	1
1 General	3
1.1 Scope	3
1.2 Applied directives and standards	4
1.3 General function description	5
1.3.1 Main features	5
1.3.2 Overall system overview	6
2 Essential safety information	7
2.1 Definition of symbols and instructions	7
2.2 General hazards when using the product	8
2.3 Intended use	9
2.4 Warranty and liability	10
2.5 Organisational measures	11
2.6 Selection and qualification of personnel; fundamental obligations	11
2.7 Safety information	12
3 Transport / storage	14
4 Assembly	15
4.1 Solid shaft version PSEN enc m2 eCAM	15
4.1.1 Requirements	15
4.2 Hollow shaft version PSEN enc m1 eCAM	17
4.2.1 Requirements	17
4.2.2 Dowel pin	19
5 Installation / Preparation for commissioning	21
5.1 EMC requirements	21
5.2 SSI communication mode	23
5.3 SSI, RS422 communication technology	24
5.4 Cable specification	26
5.5 Connection	27
5.5.1 Supply voltage, X1	28
5.5.2 Measuring systems, X2	29
5.6 Shield connection	30
5.7 Count direction	34
5.8 SSI interface	35
5.9 Incremental interface	37

5.9.1 Signal characteristic of the incremental interface	37
5.10 LED status display	39
6 SSI format.....	40
6.1 Sign of life counter	40
7 Replacing the measuring system.....	41
8 Technical details	43

1 General

This operating manual includes the following topics:

- General function description
- Essential safety information with details of intended use
- Characteristic data
- Assembly
- Installation/commissioning
- SSI interface

1.1 Scope

This operating manual applies exclusively to the following measuring systems with SSI interface:

- PSEN enc m1 eCAM
- PSEN enc m2 eCAM
- PSEN enc s1 eCAM
- PSEN enc s2 eCAM

The products are labelled via nameplates and form part of a system.

1.2 Applied directives and standards

The measuring systems PSEN enc m1 eCAM and PSEN enc m2 eCAM have been developed, designed and manufactured in compliance with the applicable European and international standards, directives and regulations.

Directives	
- 2004/108/EC (L 390/24)	EMC Directive
EMC; Immunity in accordance with EN 61000-6-2:2005, industrial environment:	
- DIN EN 61000-4-2:2009	Electrostatic discharge, ESD
- DIN EN 61000-4-3:2008	High frequency electromagnetic fields
- DIN EN 61000-4-4:2005	Fast transient electrical disturbances, burst
- DIN EN 61000-4-5:2007	Surge voltages
- DIN EN 61000-4-6:2009	Conducted disturbances, induced by high frequency fields
EMC; Emissions in accordance with EN 61000-6-3:2007, residential environment:	
- EN 55022:2006	Disturbance field strength, 30 MHz - 1 GHz
- EN 55022:2006	Interference voltage, < 30 MHz
- DIN EN 61326-3-2:2008	Immunity requirements for safety-related systems and for equipment
Environmental influences	
- DIN EN 60068-2-6:2008	Sinusoidal vibration
- DIN EN 60068-2-64:2009	Broadband noise (digitally controlled)
- DIN EN 60068-2-29:1995	Shock and continuous shock tests
- DIN EN 60529:2000	Degrees of protection, IP code
Other requirements	
- VDE 0100	Erection of low voltage installations

1.3 General function description

The rotary measuring system

- PSEN enc mx eCAM is an absolute multi-turn position measuring system with synchronous serial interface (SSI).
- PSEN enc sx eCAM is an absolute single-turn position measuring system with synchronous serial interface (SSI).

The measuring system consists of a **redundant, dual-channel system**, in which **optical** and **magnetic sensing units** are arranged on a drive shaft, designed as a hollow shaft or solid shaft.

1.3.1 Main features

- SSI interface, to output data from measuring channel 1
- SSI interface, to output data from measuring channel 2
- Measuring channel 1:
 - Single-turn: optical single-turn sensing via code disk (transmitted light)
 - Multi-turn: optical single-turn sensing via code disk (transmitted light) and magnetic multi-turn sensing
- Measuring channel 2:
 - Single-turn: magnetic single-turn sensing
 - Multi-turn: magnetic single and multi-turn sensing
- Additional incremental interface
- Mechanically, the two systems are connected only by the common drive shaft and the housing
- Measuring channels have a common voltage terminal, but are electrically isolated internally via two separate power supplies
- A common drive shaft
- 2 Installation Types:
 - Hollow shaft version: PSEN enc m1 eCAM and PSEN enc s1 eCAM
 - Solid shaft version: PSEN enc m2 eCAM and PSEN enc s2 eCAM

The optical system has greater accuracy due to the technology.

The magnetic sensing system is a fully-fledged second measuring channel and operates independently from the first measuring channel. The two measuring systems have their own SSI interfaces, which transmit the same data format.

The data from measuring channel 1 is also output via an incremental interface.

1.3.2 Overall system overview

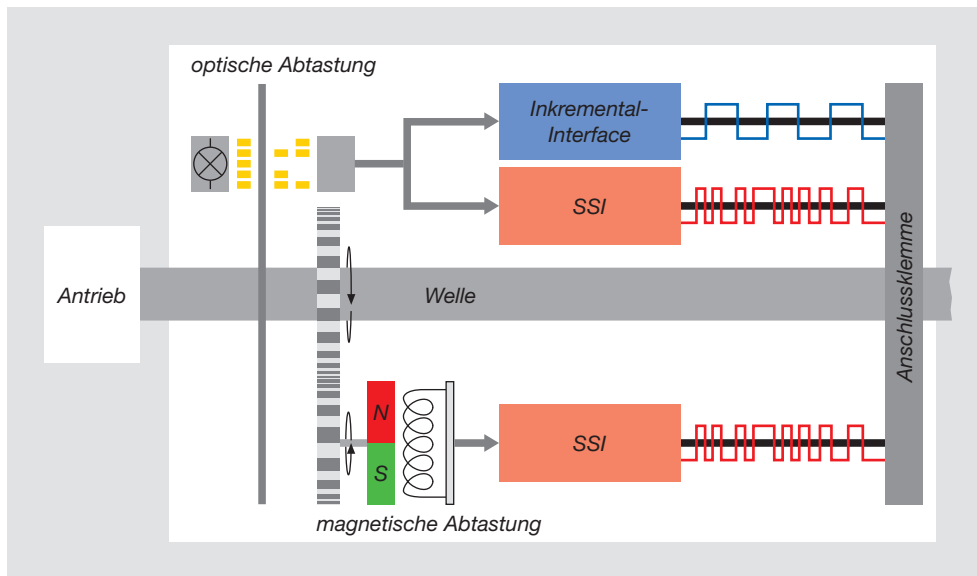

Fig. 1: System schematic

A Measuring channel 1, single-turn and multi-turn

- Optical detection of the number of steps/revolution
- Max. 8192 steps/revolution, accuracy: 13 Bit
- Synchronous serial interface (SSI)
- Incremental signals for position feedback

B Measuring channel 1, multi-turn

- Magnetic detection of the number of revolutions
- Max. 4096 revolutions
- Synchronous serial interface (SSI)

C Measuring channel 2, single-turn and multi-turn

- Magnetic detection of the number of steps/revolution
- Max. 8192 steps/revolution, accuracy: 8 Bit
- Synchronous serial interface (SSI)

D Measuring channel 2, multi-turn

- Magnetic detection of the number of revolutions
- Max. 4096 revolutions
- Synchronous serial interface (SSI)

2 Essential safety information

2.1 Definition of symbols and instructions



DANGER!

This means that death or serious injury will occur if the relevant preventive measures are not taken.



WARNING!

This means that death or serious injury can occur if the relevant preventive measures are not taken.



CAUTION!

This means that a minor injury can occur if the relevant preventive measures are not taken.



NOTICE

This means that material damage can occur if the relevant preventive measures are not taken.



INFORMATION

This indicates important information or features and application tips for the relevant product.



This means that the relevant ESD protective measures must be considered in accordance with DIN EN 100 015-1.

(Equipotential bonding between the body and the unit or housing earth via a high impedance resistor (approx. 1 MOhm) e.g. using a standard ESD arm band).

2.2 General hazards when using the product

The product, described below as the *measuring system*, is manufactured using state-of-the-art technology. ***Nevertheless, use of the system outside its intended purpose may pose a risk to the life and limb of the user or third-party or adversely affect the measuring system and other material assets!***

The measuring system should only be used when in perfect working order, in accordance with its intended use, in awareness of safety measures and hazards and in compliance with the operating manual! In particular, errors that could adversely affect safety must be rectified without delay!

2.3 Intended use

The measuring system can be used to detect angular movement and to prepare measured data for control systems within plants.

Intended use includes:

- Compliance with all the instructions in this operating manual
- Compliance with the information on the nameplate and any prohibition or instruction labels on the measuring system
- Compliance with the operating manual provided by the machine or plant manufacturer
- Operation of the measuring system within the limit values stated in the technical details
- Assurance that the failsafe processing unit (control system) fulfils all the required safety functions
- Compliance with and use of the check list in the Appendix
- Assurance that the measuring system is mounted safely on the driving axis

In particular, the system shall not be used:

- In environments with an explosive atmosphere
- For medical purposes

2.4 Warranty and liability

All claims to warranty and liability will be rendered invalid if

- The product was used contrary to the purpose for which it is intended
- Damage can be attributed to not having followed the guidelines in the manual
- Operating personnel are not suitably qualified
- Any type of modification has been made (e.g. exchanging components on the PCB boards, soldering work etc.).

2.5 Organisational measures

- The operating manual must always be kept ready-to-hand at the location where the measuring system is used
- In addition to the operating manual there are also generally applicable legal and other binding regulations regarding accident prevention and environmental protection, which must be observed and communicated.
- The respective national, local and plant-specific provisions and requirements must be observed and communicated
- It is the responsibility of the operator to advise staff of any special operational features and requirements
- Before starting work, any staff charged with operating the measuring system must have read and understood the operating manual, in particular the chapter entitled "Essential safety information".
- The nameplate and any prohibition or instruction labels on the measuring system must always be maintained in a legible condition.
- No mechanical or electrical modifications may be made to the measuring system except for those expressly described in the operating manual.
- Repairs may only be made by the manufacturer, or by a body or person authorised by the manufacturer.

2.6 Selection and qualification of personnel; fundamental obligations

- All work on the measuring system must only be carried out by qualified technical personnel.
Qualified personnel are those who have been authorised by those responsible for plant safety to carry out the necessary work, based on their training, experience and instruction, as well as their knowledge of the relevant standards, provisions, accident prevention regulations and operating conditions. They are able to identify and avoid potential hazards.
- For a definition of "Qualified personnel" you can also refer to the standards VDE 0105-100 and IEC 364 (sources: Beuth Verlag GmbH, VDE Verlag GmbH, for example).
- Responsibility for assembly, installation, commissioning and operation must be clearly defined. There is an obligation to supervise trainees or apprentices.

2.7 Safety information

Please note:

- Wiring work should only be carried out when the supply voltage is switched off; the same applies when opening and closing electrical connections.
- Do not undertake any welding operations if the measuring system is already wired / switched on.
- An appropriate heating/cooling measure should be used at the installation site to prevent the ambient temperature exceeding or falling below the permitted limit values.
- The measuring system must be installed so that direct moisture cannot affect the measuring system.
- Appropriate ventilation/venting or heating/cooling measures at the installation site must prevent values falling below the dew point (condensation).
- If an overvoltage of >36 VDC is applied inadvertently, the measuring system must be inspected on site and the reasons/circumstances stated.
- Checks must examine the potential hazards arising from interaction with other systems and devices which are or will be installed in the vicinity. It is the user's responsibility to take appropriate measures.
- The supply voltage must be protected with a fuse appropriate for the cable cross section.
- Cables must be suitable for the relevant temperature range.
- The measuring system should not be operated if it is defective.
- Ensure that the installation environment is protected from aggressive media (acids etc.).
- Shocks to the shaft (e.g. hammer blows) should be avoided during installation.
- The measuring system must not be opened.
- The nameplate specifies the technical properties of the measuring system. If the nameplate is no longer legible or is missing altogether, the measuring system must no longer be put into service.



The measuring system contains electrostatically sensitive assemblies and components, which can be damaged if handled incorrectly.

Avoid finger contact with the measuring system connection contacts and apply the relevant ESD protective measures.



Disposal

If the device is to be disposed of after its service life, the applicable country-specific regulations must be observed.

3 Transport / storage

- **Transport instructions**
 - Do not drop the device or expose it to heavy impact!
The device contains an optical system.
 - Only the original packaging should be used!
Inappropriate packaging material can result in the device becoming damaged in transit.

- **Storage**
 - Storage temperature: -30 to +80°C
 - Store in a dry place

4 Assembly

4.1 Solid shaft version

The measuring system is connected to the drive shaft via an elastic coupling. The coupling absorbs any deviations in the axial and radial direction between the measuring system and drive shaft. This prevents excessive load on the bearing. The centering collar with selective fit is used for centering in relation to the shaft. The device is fixed to the machine using three screws in the flange. All the fixing screws must be secured to stop them coming loose unintentionally.

4.1.1 Requirements

As the installation is application-dependent, the following instructions do not claim to be exhaustive.

- An appropriate coupling with positive-locking connection must be used in the application.
- The instructions and installation specifications provided by the coupling manufacturer must be observed.
- In particular you must ensure that
 - the coupling is suitable for the specified speed and the potential axial offset
 - the device must be installed on a greaseless shaft
 - the coupling and measuring system must not have an axial load
 - the clamping screws must be tightened with the torque defined by the coupling manufacturer
 - the coupling screws must be secured to stop them coming loose unintentionally.
- The coupling fixing should prevent axial slippage of the measuring system on the drive shaft, see Figure 2, **1**.
- Positive locking using a parallel key/groove combination (Fig. 2, **2**) should prevent radial slippage of the measuring system on the drive shaft; a coupling with groove should be used for this purpose.

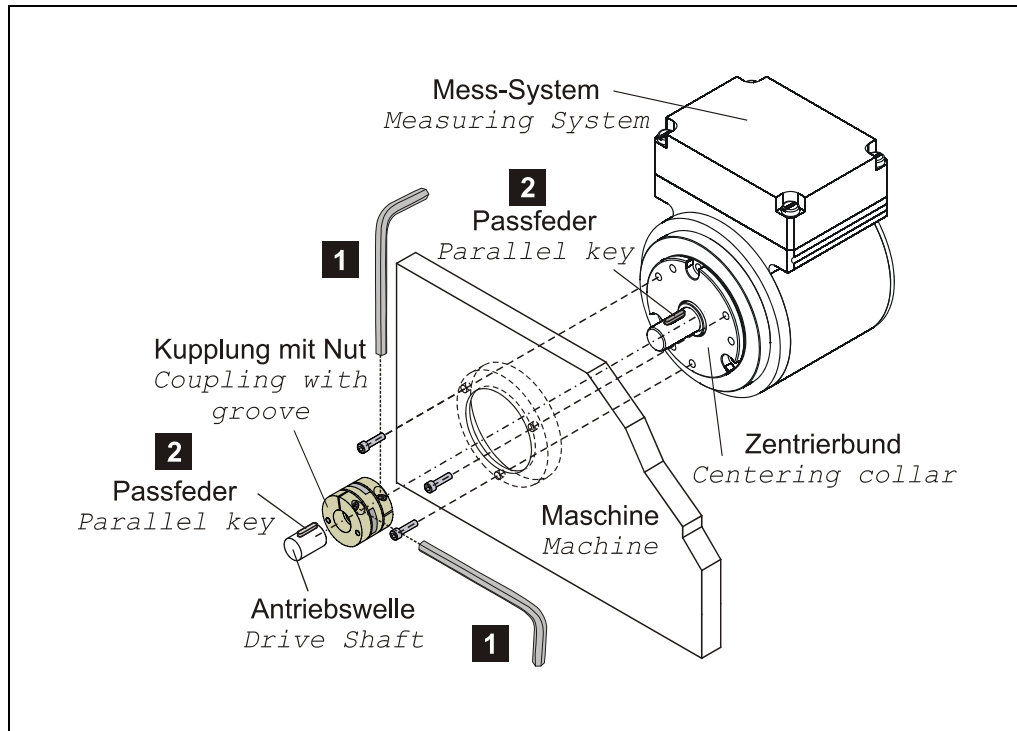

Fig. 2: Flange assembly

4.2 Hollow shaft version

4.2.1 Requirements

As the installation is application-dependent, the following instructions do not claim to be exhaustive.

- The measuring system should be installed on a greaseless shaft.
- The clamping ring fixing should prevent axial slippage of the measuring system on the drive shaft, see Figure 3.
- Additional measures may be required to prevent axial slippage of the measuring system.
- The clamping of the measuring system must not have an axial load.
- The screw on the clamping ring must be tightened to 3 Nm using a torque wrench.
- The screw on the clamping ring must be secured to stop it coming loose unintentionally.
- Positive locking using a parallel key/groove combination should prevent radial slippage of the measuring system on the drive shaft; the measuring system must be fixed to the drive side using a dowel pin, see Fig. 4.

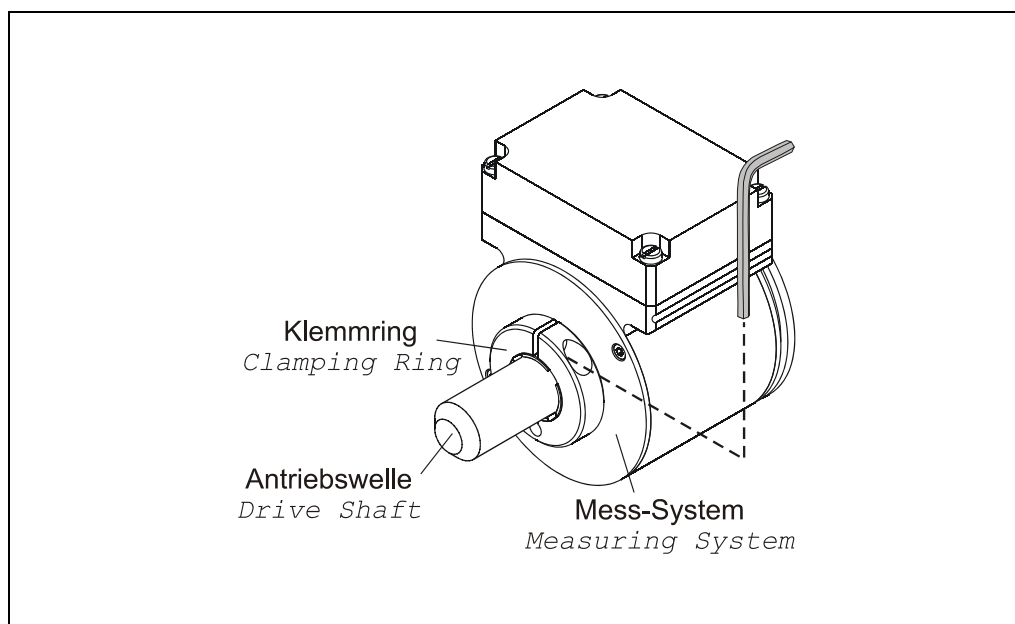

Fig. 3: Friction locking

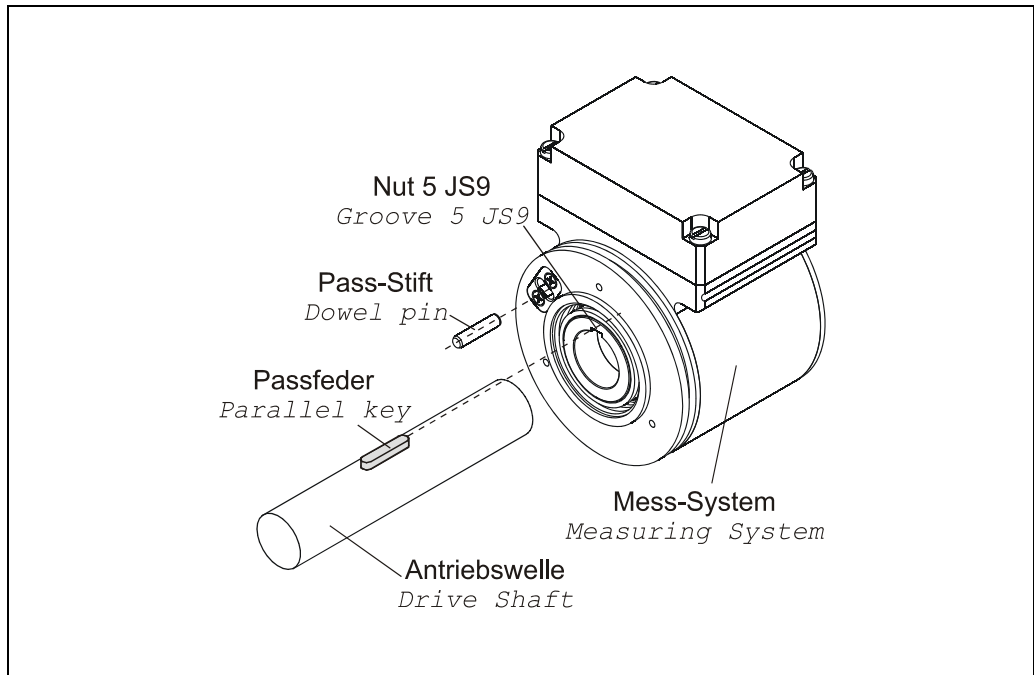

Fig. 4: Positive locking

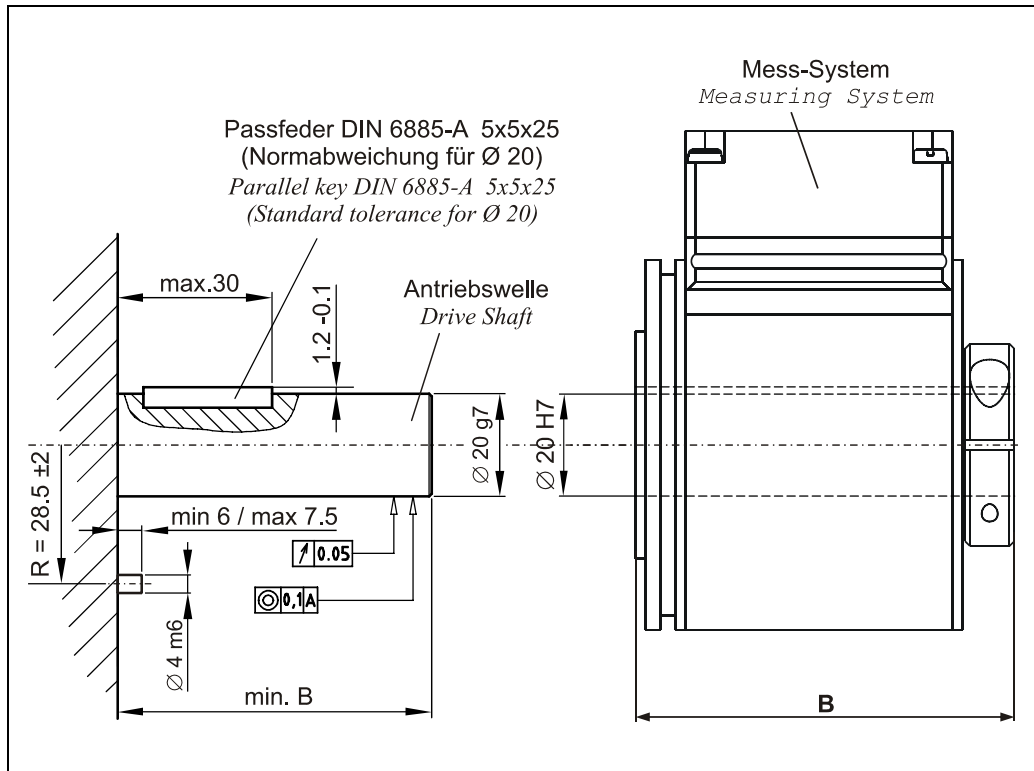

Fig. 5: Requirements of the shaft mounting

4.2.2 Dowel pin

Simultaneous rotation of the measuring system, caused by the resulting torque, is prevented by a dowel pin on the machine side. The measuring system has a 6 mm deep 4K7 groove insertion on the back to hold the dowel pin. The dowel pin must reach at least 4 mm into the groove insertion.

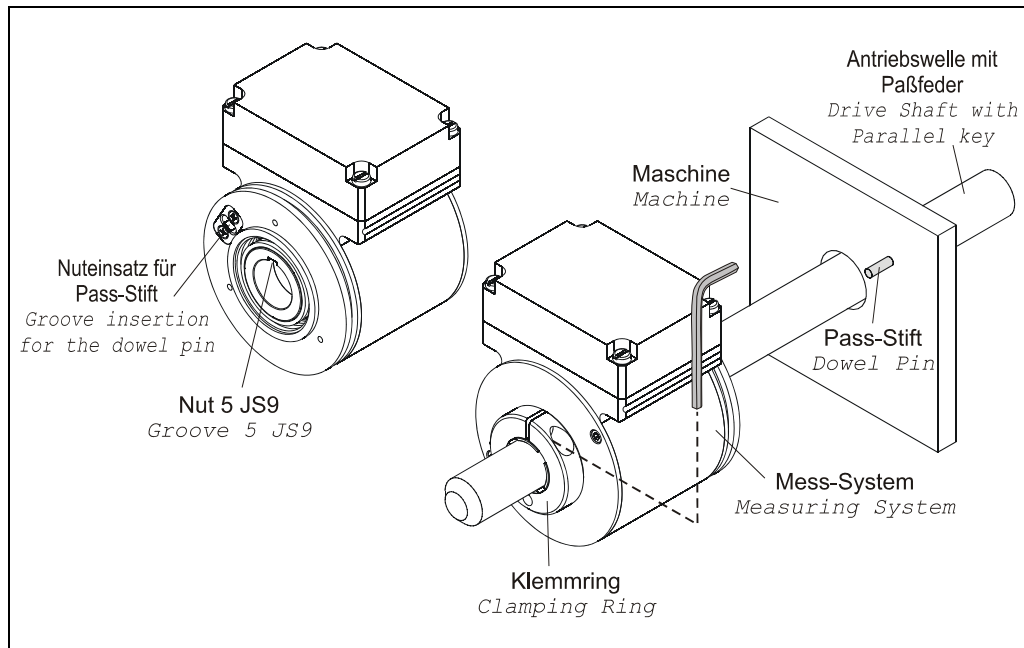

Fig. 6: Using a dowel pin to prevent simultaneous rotation

When inserting the measuring system, position it so that the dowel pin is seated correctly in the groove insertion. By tightening the clamping ring with the Allen key, the measuring system is protected against slippage on the shaft.

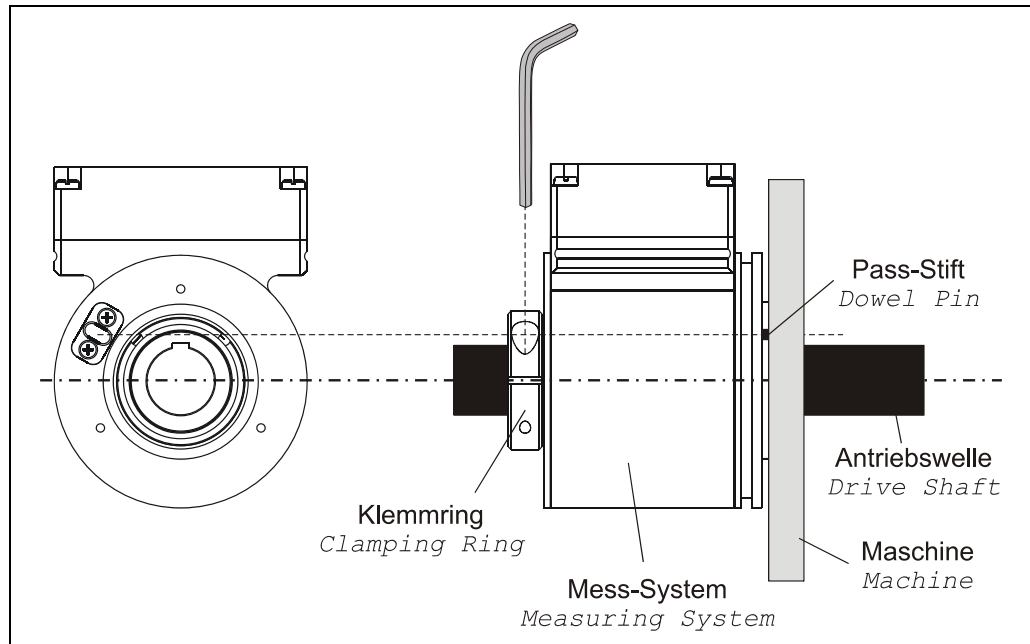

Fig. 7: Assembly schematic

5 Installation / Preparation for commissioning

5.1 EMC requirements



CAUTION!

Invalid measurement values due to radiated and conducted interference!

- Radiated interference from hand-held radios, lightning strikes on the network, mobile phones and emissions from individual devices can cause the measuring system to malfunction.
-

- In particular, sources of conducted interference such as frequency-controlled drives (circuit feedback) have a negative effect on the function of the measuring system.
 - The 24 V power supplies must comply with SELV/PELV.
 - The shielding effect of cables must also be guaranteed after installation (bending radius!) and after changing connectors. If in doubt, use a more flexible cable with a higher current carrying capacity.
 - For the drive/motor cabling, use a 5-core cable on which the PE conductor is separate from the N-conductor (TN network). This will largely prevent equipotential bonding currents and the development of interference.
 - Shielded, stranded data cable must be used to make the system highly resistant to electromagnetic interference. Where possible, the shield should be connected to the protective earth **at both ends** and with good conductivity using large screen clamps. Only if the machine earth is subjected to heavy interference in comparison with the control cabinet earth should the shield only be earthed **at one end** in the control cabinet.
 - Equipotential bonding measures must be provided for the whole of the plant's processing chain.
 - Power and signal cables should be laid separately.
 - Comply with the manufacturer's instructions when installing converters and shielding the power cables between the frequency converter and motor.
 - The energy supply should be adequately dimensioned.
 - The measuring system should be separated or segregated from potential interfering transmitters.
 - Use of filters should be envisaged.
 - Internal and external protection against lightning should be considered.
 - The plant installer must adapt the cable routing to local conditions.



Compliance with the relevant standards and directives is essential to guarantee safe, interference-free operation!

In particular, compliance with the applicable EMC Directive and shielding / earthing guidelines should be guaranteed!

5.2 SSI communication mode

SSI mode is a synchronous serial communication mode for the position of the measuring system. By using the RS422 interface for communication, sufficiently high transmission rates can be achieved.

The measuring system receives a sequence of clock signals from the data receiver (control system) and responds with the current position value, which is transmitted serially and synchronously with the sent clock pulse.

As data transfer is synchronised by the start of the clock signals, it is not necessary to use single-step codes such as Gray code, for example.

The data signals Data+ and Data- are sent using cable transmitters (RS422). The clock signals Clock+ and Clock- are received via optocouplers to protect against damage resulting from interference, potential differences or reverse polarity.

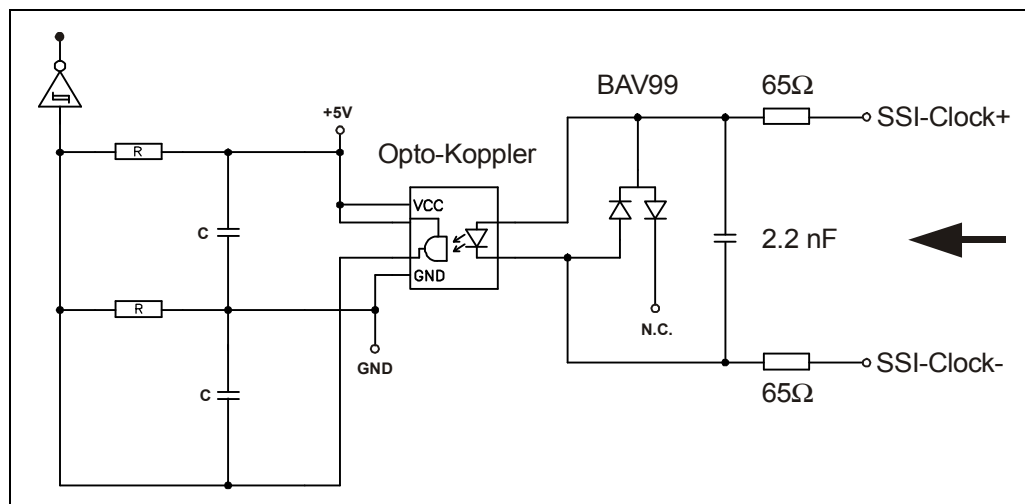

Fig. 8: SSI principle input circuit (Key: Opto-Koppler – Optocoupler)

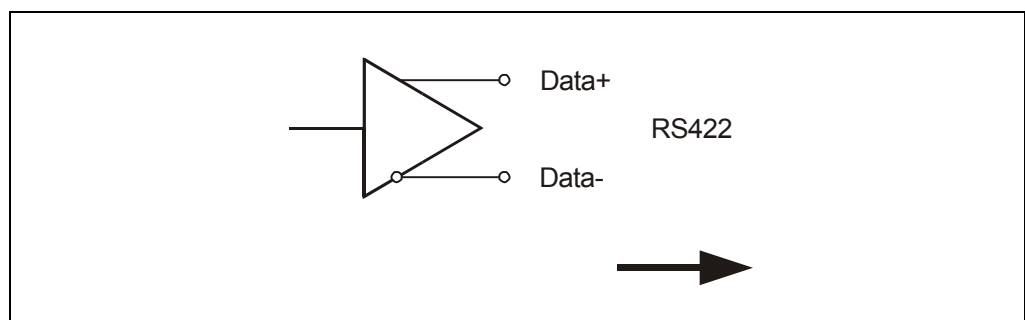

Fig. 9: SSI output circuit

5.3 SSI, RS422 communication technology

RS422 communication requires one cable pair for the signals Data+ and Data- and one cable pair for the signals Clock+ and Clock-.

The serial data is transmitted without reference to earth as a voltage difference between two corresponding cables.

The receiver simply evaluates the difference between two cables, so that common-mode interference on the transmission line does not corrupt the usable signal.

By using shielded stranded pair cable, data transmission can be realised over distances of up to 500 metres at a frequency of 100 kHz.

Under load, RS422 transmitters provide output levels of ± 2 V between the two outputs; the receivers still recognise levels of ± 200 mV as a valid signal.

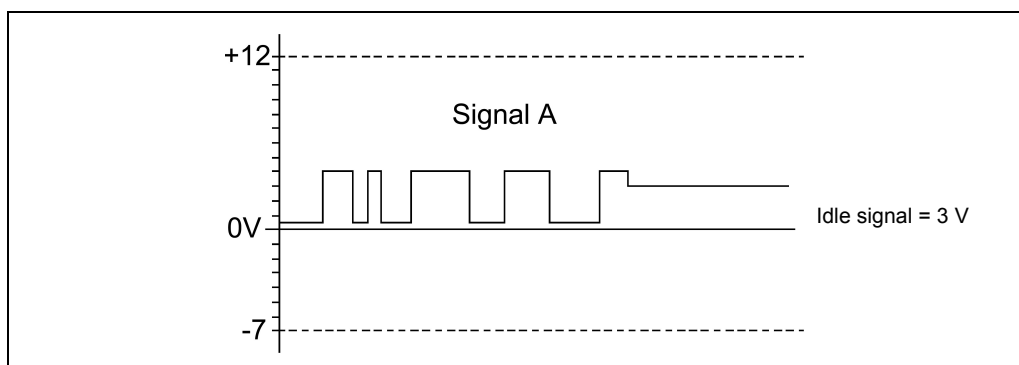
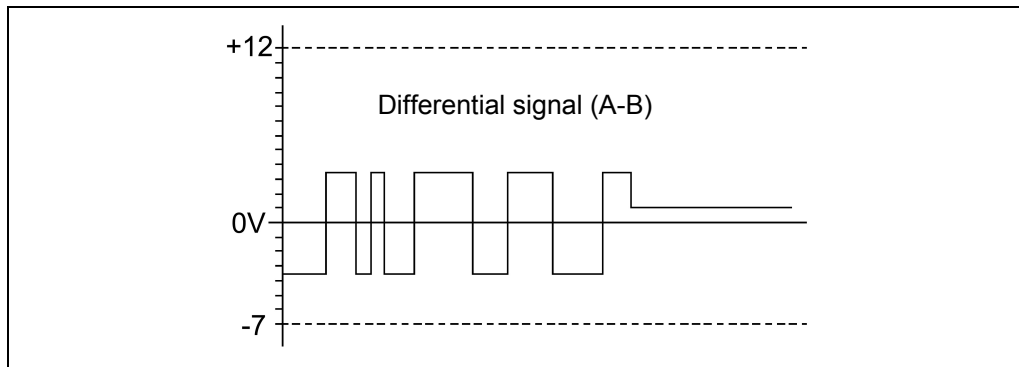

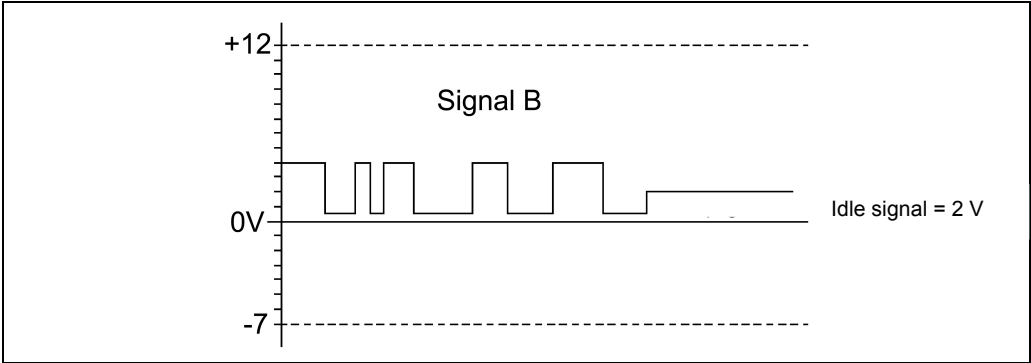

5.4 Cable specification

Signal	Cable specification
Data+ / Data- (RS422+ / RS422-)	Min. 0.25 mm ² , shielded stranded pair
Clock+ / Clock- (RS422+ / RS422-)	
A+ / A-	Min. 0.25 mm ² , shielded stranded pair
B+ / B-	
Supply +24 VDC / 0 V	Min. 0.5 mm ² , shielded stranded pair

The maximum cable length depends on the SSI clock frequency and cable composition and should match the table below.

Please note that an additional delay time t_v (Data+/Data-) of approx. 6 ns should be calculated per metre of cable.

SSI clock frequency [kHz]	810	750	570	360	220	120	100
Cable length [m]	Approx. 12.5	Approx. 25	Approx. 50	Approx. 100	Approx. 200	Approx. 400	Approx. 500

5.5 Connection

Connection data, terminal block X1, X2:

- Version with slider mechanism
- Grid dimension: 2.5 mm
- Cable cross section, strand: 20-28 AWG
- Rated current: 6 A

Handling:

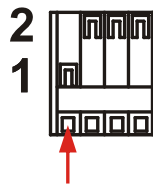

- Move slider mechanism to "1"
- Insert strand
- Move slider mechanism to "2" and lock

Terminal assignment:

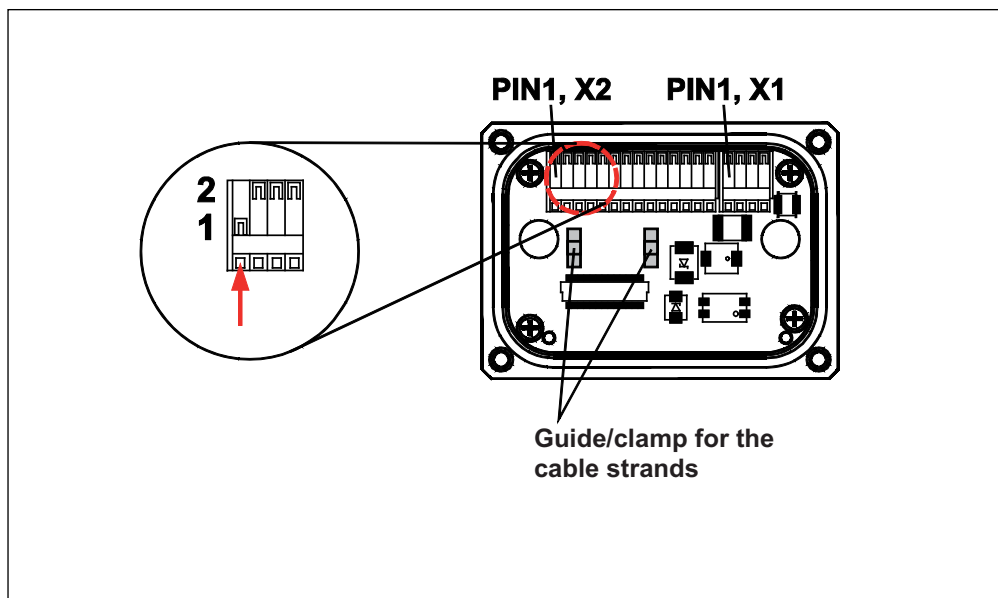

Fig. 10: Connection cover open

5.5.1 Supply voltage, X1



NOTICE

Risk of undetected damage to the internal electronics due to incorrect overvoltages!

- If an overvoltage of >36 VDC is applied inadvertently, the measuring system must be inspected on site.
 - The measuring system must be taken out of service immediately
 - If returning the measuring system, the reasons or circumstances under which the overvoltage occurred should be stated
 - The power supply must satisfy the requirements in accordance with SELV/PELV (IEC 60364-4-41:2005)

PIN	Signal	Description	
1	+ 24 VDC (11...28 VDC)	Supply voltage	PIN 1/2 through-connected
2	+ 24 VDC (11...28 VDC)	Supply voltage	
3	0 V	GND	PIN 3/4 through-connected
4	0 V	GND	

Optical sensing unit and magnetic sensing unit have a common supply, but are electrically isolated internally via two separate power supplies.

5.5.2 Measuring systems, X2

PIN	Signal	Description
1	N.C.	Do not connect!
2	INK A-	Channel A -, RS422
3	INK A+	Channel A +, RS422
4	N.C.	Do not connect!
5	INK B-	Channel B -, RS422
6	INK B+	Channel B +, RS422
7	SL_m -	Data -, measuring channel 1, differential RS422
8	SL_m +	Data +, measuring channel 1, differential RS422
9	MA_m -	Clock -, measuring channel 1, differential RS422
10	MA_m +	Clock +, measuring channel 1, differential RS422
11	SL_s -	Data -, measuring channel 2, differential RS422
12	SL_s +	Data +, measuring channel 2, differential RS422
13	MA_s -	Clock -, measuring channel 2, differential RS422
14	MA_s +	Clock +, measuring channel 2, differential RS422

5.6 Shield connection

The shield connection is made via special EMC-compliant cable screw connections, in which the cable shield can be connected internally.

Cable screw connection assembly, type A

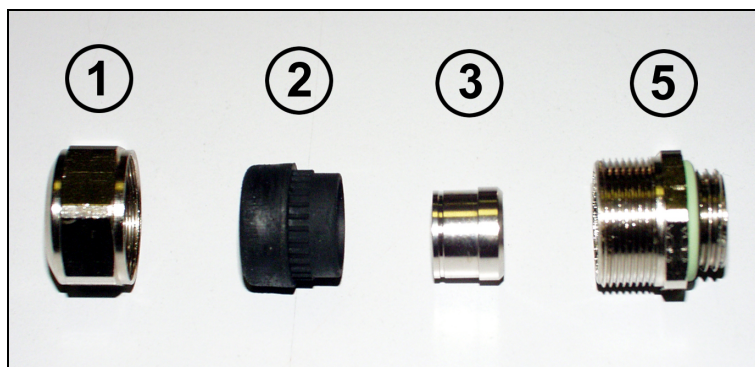

- Pos. 1 Union nut
- Pos. 2 Sealing insert
- Pos. 3 Contact sleeve
- Pos. 5 Screw socket

1. Trim the shield braid / shield foil to the **dimension "X"**.
2. Slide the union nut (1) and sealing insert / contact sleeve (2) + (3) over the cable.
3. Bend the shield braid / shield foil by approx. 90° (4).
4. Slide the sealing insert / contact sleeve (2) + (3) up to the shield braid / shield foil.
5. Fit the screw socket (5) on the housing.
6. Push the sealing insert / contact sleeve (2) + (3) flush into the screw socket (5).
7. Screw the union nut (1) to the screw socket (5).

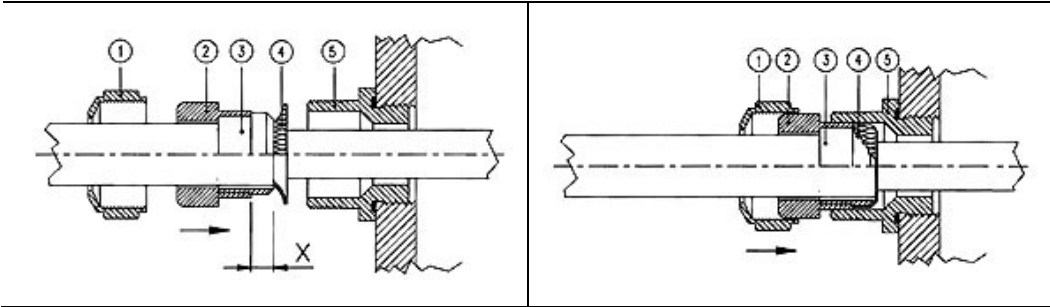

Cable screw connection assembly, type B

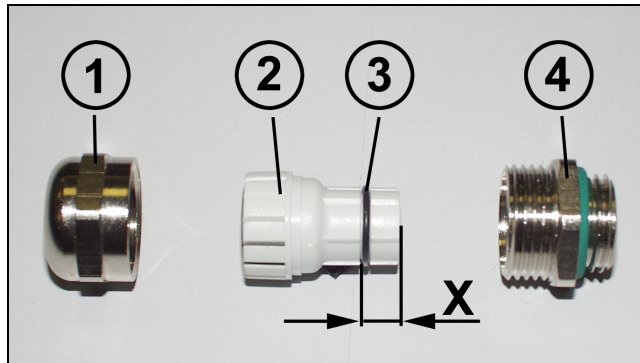

- Pos. 1 Union nut
- Pos. 2 Clamping insert
- Pos. 3 Inner O-ring
- Pos. 4 Screw socket

1. Trim the shield braid / shield foil to the **dimension "X" + 2 mm**.
2. Slide the union nut (1) and clamping insert (2) over the cable.
3. Bend the shield braid / shield foil by approx. 90°.
4. Slide the clamping insert (2) up to the shield braid / shield foil and wrap the braid back around the clamping insert (2), so that the braid goes over the inner O-ring (3) but not over the cylindrical part or the torque supports.
5. Fit the screw socket (4) on the housing.
6. Push the clamping insert (2) into the screw sockets (4), so that the torque supports fit into the lengthwise slots provided in the screw socket (4).
7. Screw the union nut (1) to the screw socket (4).

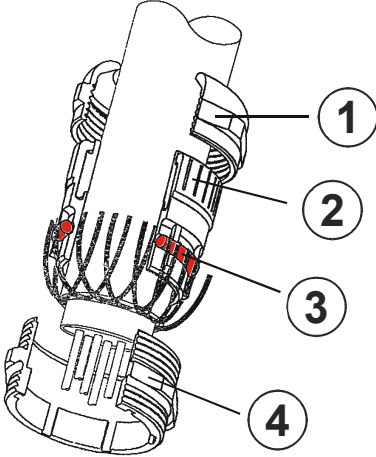

5.7 Count direction

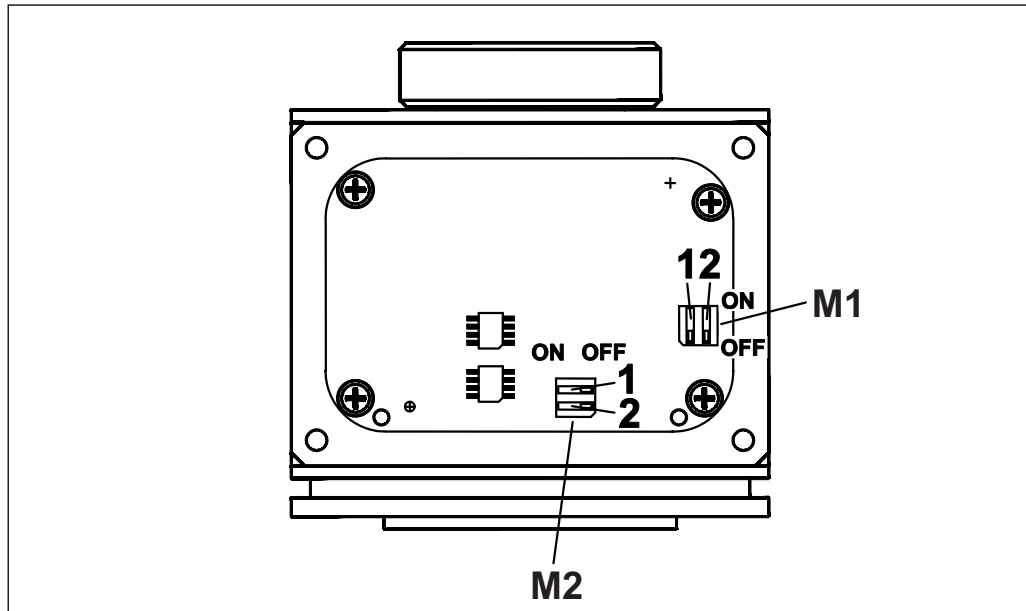

Fig. 11: Setting the count direction

M1: Setting for measuring channel 1

M2: Setting for measuring channel 1

Permitted switch settings measuring channel 1/ measuring channel 2:

DIP 1	DIP-Schalter 2	Count direction
OFF	ON	Increasing in clockwise direction, viewed towards the flange connection
ON	OFF	Decreasing in clockwise direction, viewed towards the flange connection



NOTICE

The count direction for measuring channel 1 and measuring channel 2 must be set in opposite direction!

5.8 SSI interface



NOTICE

Risk of damage to subsequent electronics due to overvoltages caused by a missing earth reference point!

- If the earth reference point is missing entirely, e.g. 0 V of the power supply is not connected, voltages equal to the level of the supply voltage can occur at the outputs of this interface.
- An earth reference point must be guaranteed to be present at all times.

In the rest condition, Data+ and Clock+ are high. This corresponds to the time before Point **1** in the diagram below.

The first time the clock signal changes from high to low **1**, the internal retriggerable monoflop is set with the monoflop time t_M .

The time t_M determines the lowest transmission frequency ($T = t_M / 2$). The upper cut-off frequency is calculated from the sum of all the signal run times and is also limited by the built-in filter circuits.

With each additional falling clock edge, the active status of the monoflop is extended by the time t_M ; this is the case by Point **4** at the latest.

By setting the monoflop **1**, the bit-parallel data present on the internal parallel-serial converter is stored in an input latch of the shift register via an internally generated signal. This ensures that the data does not change as the position value is transmitted.

The first time the clock signal changes from low to high **2**, the most significant bit (MSB) of the device information is connected to the serial data output. With each additional rising edge, the next lower value bit is moved to the data output.

When the clock sequence is complete, the data lines are held at 0 V (Low) for the duration of the monoperiod t_M **4**. This is also used to calculate the minimum pause time t_p that must be maintained between two consecutive pulse sequences and amounts to $2 * t_M$.

The data is read in by the evaluation electronics from the first rising clock edge. Based on various factors, a delay time of $t_v > 100$ ns results, without cable. As a result, the measuring system moves the data to the output after the delay time t_v . For this reason, a "Pause-1" is read in at Point **2**. This must be rejected or can be used in conjunction with a "0" after the LSB data bit for open circuit monitoring. The MSB data bit is not read in until Point **3**. For this reason, the number of clock pulses must always be one higher (n+1) than the number of data bits to be transmitted.

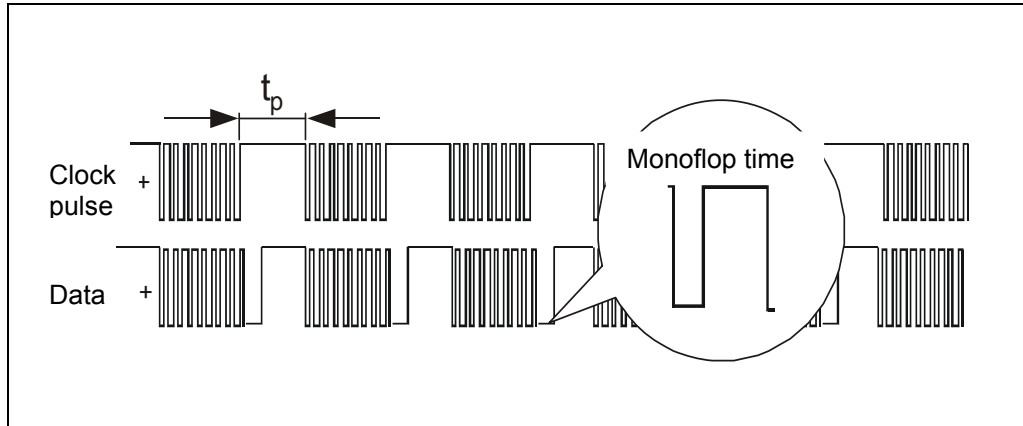

Fig. 12: Typical SSI communication sequences

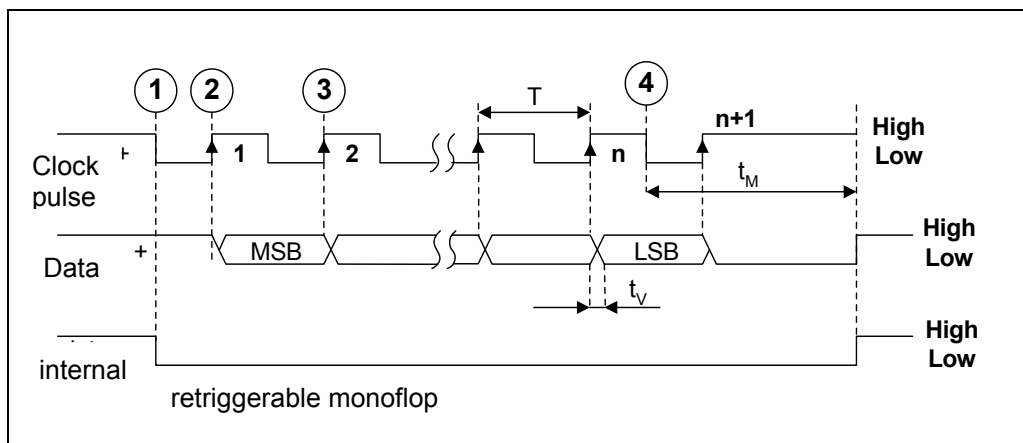

Fig. 13: SSI communication format

5.9 Incremental interface

To output the absolute position, the standard version of the measuring system also has an incremental interface in addition to the SSI interface.

- The measuring system checks the outputs on this interface for external voltage sources. The measuring system is shut down if voltages > 5.7 V arise. In this state, the measuring system behaves as though it were not connected.
- The interface is generally used for position feedback on motor control applications.



NOTICE

Risk of damage to subsequent electronics due to overvoltages caused by a missing earth reference point!

- If the earth reference point is missing entirely, e.g. 0 V of the power supply is not connected, voltages equal to the level of the supply voltage can occur at the outputs of this interface.
- An earth reference point must be guaranteed to be present at all times.

5.9.1 Signal characteristic of the incremental interface

A corresponding number of pulses is output while completing a revolution. To evaluate the count direction, a 2nd signal sequence with 90° phase offset is output for the controller.

On the standard version, the incremental resolution of the measuring system is 4096 pulses / revolution. There is no zero pulse.

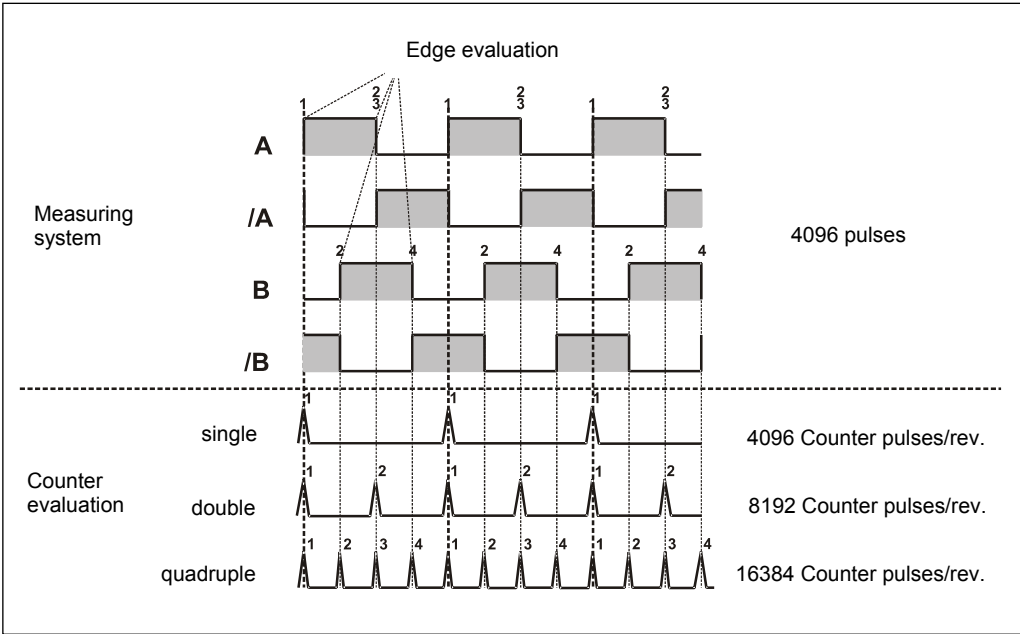

Fig. 14: Counter evaluation)

5.10 LED status display

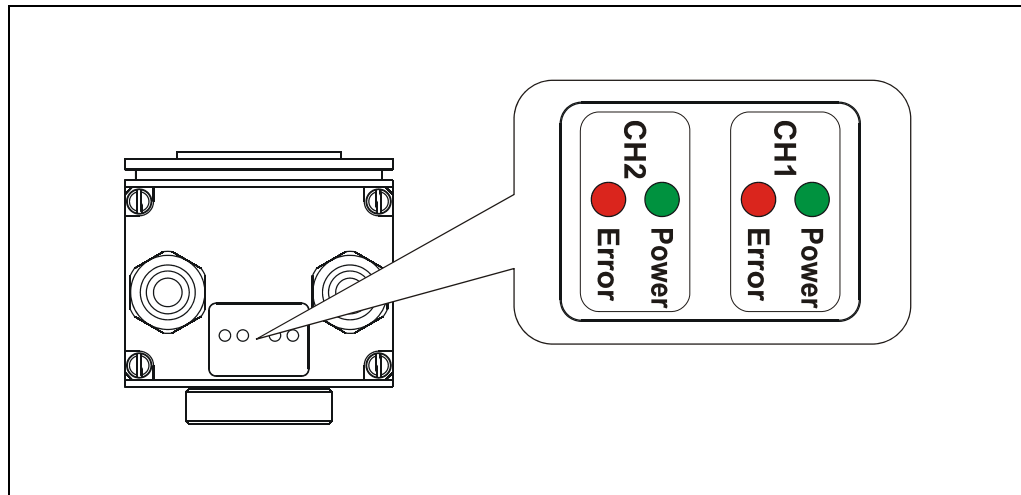

Fig. 15: LED status display

Power LED, green	CH1: Measuring channel 1, CH2: Safety system
OFF	Supply voltage absent or outside the range 11...28 VDC, hardware error
ON	Ready for operation, normal condition

Error LED, red	CH1: Measuring channel 1, CH2: Safety system
OFF	Ready for operation, no fault
ON	Fault condition; general fault indicator for faults which result in the data output being shut down. Exception: If there is a fault in the incremental channel, the LED is also ON, but the SSI remains operational.

6 SSI format

6.1 Multi-turn

Bit 0-11		Bit 12-24		Bit 25-39		LSB	
MSB							
MT, 12 Bit	ST, 13 Bit	Err1, 1Bit	Err2, 1 Bit	SoL, 5 Bit	8 Bit		
Multi-turn resolution	Single-turn resolution	Error bit Measuring channel 1	Error bit Measuring channel 2	Sign of life counter	Reserved		
$2^{24}-2^{13}$	$2^{12}-2^0$	2^0	2^0	2^4-2^0	2^7-2^0		

Both measuring system channels use the same SSI data format.

6.2 Single-turn

Bit 0-12		Bit 13-16		Bit 17	Bit 18	Bit 19-23		Bit 24-31	
MSB								LSB	
ST, 13 Bit	4 Bit		Err1, 1Bit	Err2, 1 Bit	LZZ, 5 Bit	8 Bit			
Single-turn resolution	Place holder		Error bit Measuring channel 1	Error bit Measuring channel 2	Sign of life counter	Reserved			
$2^{12}-2^0$	2^3-2^0		2^0	2^0	2^4-2^0	2^7-2^0			

Both measuring system channels use the same SSI data format.

6.3 Sign of life counter

The 5-Bit sign of life counter is incremented based on the scanning procedures and is inserted into the SSI telegram.



INFORMATION

The sign of life counter is increased when the control system has fetched the current position values and, internally, new position values have been generated and provided. In other words, if the sign of life counter has been incremented in relation to the previous telegram, this guarantees that the current data transmitted originates from a new position scanning operation.

7 Replacing the measuring system

The following points must be noted when replacing the measuring system:

- The new measuring system must have the same item number as the system being replaced. Any deviations from this must be cleared with Pilz.
- You must ensure that the count direction set via hardware switches on the new measuring system matches the previous count direction.
- The new measuring system must be installed in accordance with the specifications and requirements stated in the chapter entitled “Assembly”.
- The new measuring system must be connected in accordance with the specifications stated in the chapter entitled “Connection/Shield connection”.
- When recommissioning the replaced measuring system, a protected test run must be carried out to ensure the system functions correctly.

Technical details	
Electrical data	
Supply voltage U_B DC	24 V
Power consumption at U_B DC	3.6 W
Polarity protection	yes
Scanning principle	magnetic, optical
Absolute values, measuring channel 1	
Interface	SSI
Output driver	RS422
Resolution per revolution	13 Bit
Number of revolutions	12 Bit No. 544021, 544022
Update rate	250 μs
Coding	Binary
Absolute values, measuring channel 2	
Interface	SSI
Output driver	RS422
Resolution per revolution	8 Bit
Number of revolutions	12 Bit No. 544021, 544022
Update rate	500 μs
Coding	Binär
Incremental values	
Interface	TTL
Signal level	5 V
Number of increments	4096
Signal tracks	A, /A, B, /B
Environmental data	
Vibration to EN 60068-2-6	
Frequency	55.0 - 2000.0 Hz
Max. acceleration	10g
Shock to EN 60068-2-27	
Shock acceleration	60g
Shock time	6 ms
Continuous shock test	25g, 6ms
Ambient temperature	-20 - 70 °C
Storage temperature	-30 - 80 °C
Climatic suitability	98 %
Protection type	EN 60529
Housing	IP54
Mechanical data	
Housing material	Aluminium
Shaft design	Hollow shaft No. 544011, 544021 Solid shaft No. 544012, 544022
Shaft diameter	10 mm No. 544012, 544022 20 mm No. 544011, 544021
Connection type	Terminals
Connection direction	radial
Angular acceleration	1E+04 rad/s²
Max. speed	3000 1/min No. 544011, 544021 6000 1/min No. 544012, 544022
Torque on start-up	0.006 Nm No. 544012, 544022 0.060 Nm No. 544011, 544021

Mechanical data

Axial shaft load capacity	50 N No. 544012, 544022
Radial shaft load capacity	90 N No. 544012, 544022
Mechanical service life	3.9 x 10¹⁰
Weight	850 g No. 544012, 544022 950 g No. 544011, 544021



► ...

In many countries we are represented by our subsidiaries and sales partners.

Please refer to our homepage for further details or contact our headquarters.

► Technical support

+49 711 3409-444
support@pilz.com

pilz

InduracNET p[®], Pilz[®], PIT[®], PMCprotego[®], PMI[®], PNOZ[®], Primo[®], PSEN[®], PSS[®], PVIS[®], SafetyBUS P[®], SafetyEYE[®], SafetyNET p[®], the spirit of safety[®] are registered and protected trademarks of Pilz GmbH & Co. KG in some countries. We would point out that product features may vary from the details stated in this document, depending on the status at the time of publication and the scope of the equipment. We accept no responsibility for the validity, accuracy and entirety of the text and graphics presented in this information. Please contact our Technical Support if you have any questions.